

# EXTRUDER VACUUME SYSTEM

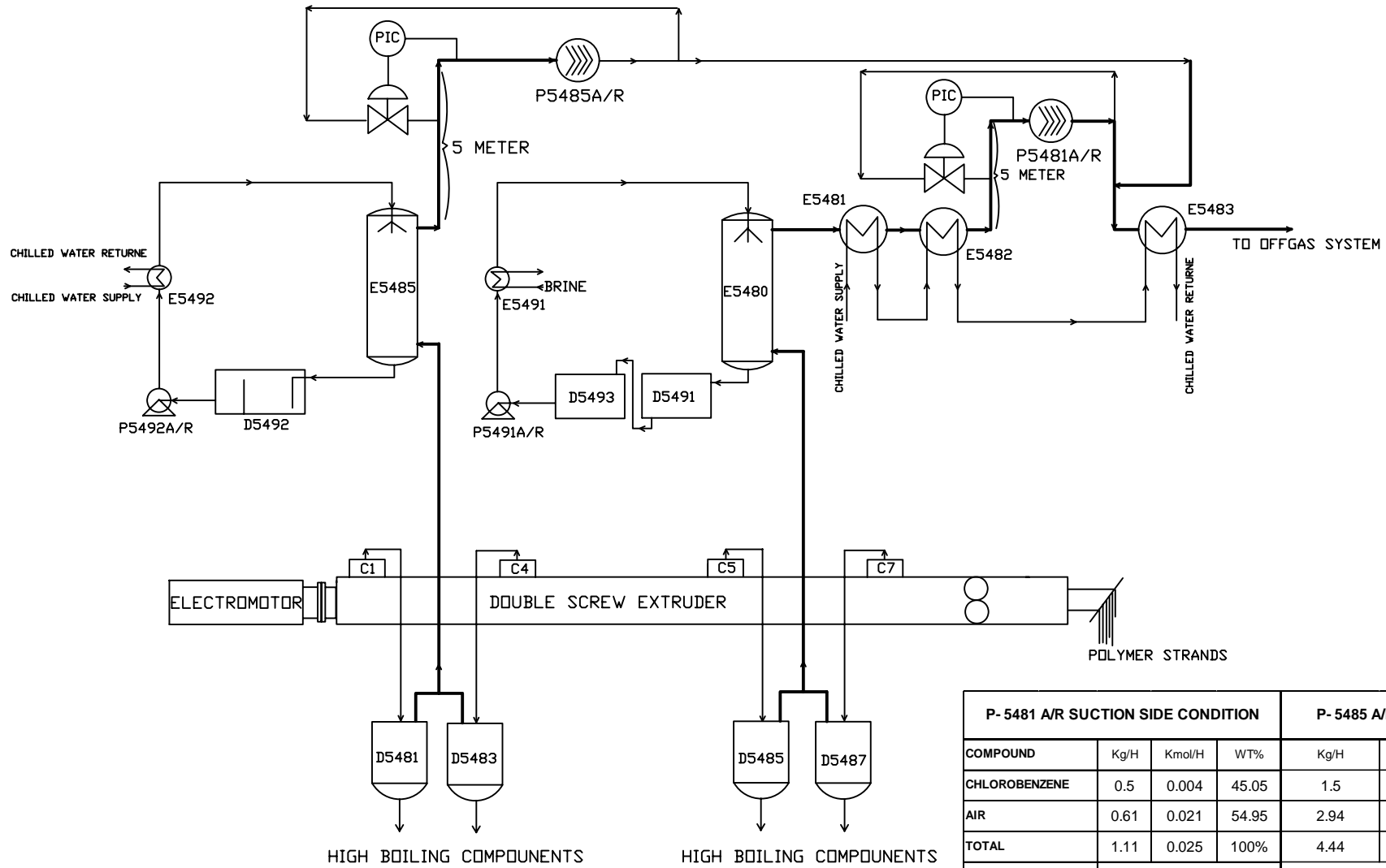

P- 5481 A/R SUCTION SIDE CONDITION				P- 5485 A/R SUCTION SIDE CONDITION		
COMPOUND	Kg/H	Kmol/H	WT%	Kg/H	Kmol/H	WT%
CHLOROBENZENE	0.5	0.004	45.05	1.5	0.013	33.78%
AIR	0.61	0.021	54.95	2.94	0.101	66.22%
TOTAL	1.11	0.025	100%	4.44	0.115	100%
CONDITION	VAPOUR			VAPOUR		
TEMPERATURE (°C)	14			45		
PRESSURE (bar a)	0.005			0.37		
VOLUME FLOW (m <sup>3</sup> /h)	120			8.2		