

ELMO gas ring vacuum pumps/compressors

Instructions

2BH1 3..

2BH1 4..

2BH1 5..

2BH1 6..



Single-stage design



Two-stage design

General notes

Machines marked **CE**, if used as intended, satisfy the requirements of the EC Directive relating to machinery 89/392/EEC (see EC Conformity Declaration, Fig. 5).

 **WARNING** Due attention must be given to the information and instructions contained in all operating and other instructions. This is essential for the avoidance of **hazards and damage!** The attached supplementary safety bulletin (610.43083.21/yellow) contains further safety information.

Special versions and design variants may differ in technical details. In case of doubt, you are urged to consult the manufacturer, quoting the **type designation and serial number** (No E ..., see rating plate), or to arrange for maintenance to be carried out by a Siemens service centre.

1 Description

1.1 Application

Intended use: The single-stage and multi-stage gas ring vacuum pumps/compressors (ELMO-G) are suitable for handling air and other non-flammable, non-corrosive and non-explosive gases.

ELMO-G units are designed for continuous operation. In the case of frequent switching or high ambient temperatures, pay attention to the maximum permissible temperature rise. Details on request.

Solids and impurities must be eliminated before entering ELMO-G units (intake filter).

ELMO-G units with EEx e drive motors may be used in rooms occasionally exposed to explosive gases. Explosive gases must not be conveyed. Please note the temperature class indicated on the rating plate.

1.2 Suction and compression pressures

The drive motors can be loaded to the total differential pressures given (Fig. 1.1 to Fig. 1.4) at +25°C and +40°C gas inlet and ambient temperatures. Fit a pressure control valve in the intake line or discharge line for heavy throttling.

The total differential pressure values given apply only if the cooling system of the ELMO-G unit is functioning **perfectly**.

The highest permissible pressure inside the ELMO-G

$$p_{\text{int max}} = 2 \text{ bar abs.}$$

At this pressure, the performance of ELMO-G units may suffer considerable.

1.3 Measuring surface sound pressure level

For information about the measuring surface sound pressure level, see Fig. 1.1 to Fig. 1.4.

1.4 Temperatures

The maximum permissible ambient temperature and gas temperature at the inlet is +40°C (ELMO-G units for warmer gases available on request).

2 Operation

2.1 Transport, storage

When lifted by crane, ELMO-G units must be secured at the eye-bolt on the pump casing.

Pay attention to the load-bearing capacity of the hoisting equipment! For ELMO-G weight data, see Fig. 1.1 to Fig. 1.4.

The **rolling-contact bearings** should be regreased, or enclosed, rolling-contact bearings should be replaced with new ones if more than four years have elapsed between delivery and machine commissioning under favourable circumstances (storage in a dry, dust-free and vibration-free room). Under unfavourable circumstances, this period is considerably reduced.

2.2 Installation

ELMO-G units can be installed and mounted in any axial position. Quiet vibration-free running is achieved by means of firm foundation or stable mounting conditions. Do not obstruct the cooling system. Keep ventilation gratings and openings clear. The direction of flow is indicated by an arrow. Opposite direction of rotation and thus opposite direction of flow available on request.

If the compressor is mounted on its cover 2.030 (Fig. 2) or near to a wall, the minimum clearance to the front of the cover should be for:

| | |
|------------|-------|
| 2BH 13.. : | 20 mm |
| 2BH 14.. : | 20 mm |
| 2BH 15.. : | 20 mm |
| 2BH 16.. : | 30 mm |

On the discharge side, the cover 2.030, centre section 2.072, graded tube 8.049 and silencer casing 8.403 must not come into contact with flammable materials (wood, etc.).

After installation, the eye-bolts must be tightened or removed.

The flow noise is reduced by built-in silencers. In the case of free gas intake or exhaust, the noise can be further reduced by attaching additional silencers (available as accessories). In order to reduce noise emission even further, ELMO-G units should not be attached to components that conduct or radiate sound (such as thin walls, metal plates, etc.). If necessary, provide intermediate sound-absorbent layers.

Piping must be installed so as to avoid strain on the ELMO-G unit.

2.3 Electrical connection

 **WARNING** The electric power must be disconnected before any work is performed on the equipment.

The system voltage and frequency must be the same as stated on the rating plate. ±5% voltage - and / or ±2% frequency deviations from the rated values are permitted without the necessity of derating the output. The links should be arranged and connected according to the circuit diagram in the terminal box. The protective earth conductor should be connected to the  terminal.

The terminal box is made of non-conductive plastic material. Because of this, the cable entries for motors up to 2.2 kW/50 Hz and 2.55 kW/60 Hz must be fitted with cable glands or screw plugs of non-conductive material. (Does not apply to EEx e drive motors).

2.4 Commissioning



Caution: Fire hazard!

High surface temperatures of more than 80 °C can occur at the machines. No heat-sensitive parts, such as normal leads or electronic components, must make contact with or be attached to them. If necessary, touch protection measures must be provided!

The rated motor currents apply for +40°C gas inlet and ambient temperatures. At gas inlet and ambient temperatures of +25°C, a 6% higher motor current is permissible.

Select motor circuit-breakers to match the rated motor current. Where **converters** are used in the incoming power supply, high-frequency current and voltage harmonics in the motor feeders can cause electromagnetic interference. That is why shielded feeders are recommended.

Exceeding the **operating speed** (see rating plate) worsens performance with respect to noise and vibration, and also shortens the useful life of bearing grease and/or the bearing replacement interval. To prevent damage arising from excessive speeds, it is advisable to consult the manufacturer concerning speed limits.

NOTE: ELMO-G units must not be operated with closed intake or outlet nozzles.

3 Maintenance

NOTE: Concerning motors whose condensate drain holes have been sealed (e.g. for type of protection IP55 or IP56, see rating plate), these holes must be opened from time to time to drain any condensate that might have accumulated.

Condensate drain holes must always be at the lowest point on the motor.

3.1 Cleaning

Outside:

When there are any deposits of fluff or dust, clean the entire surface of the ELMO-G unit. For this purposes, remove the compressor cowl 2.087 (if fitted) after releasing clip 2.129 and replace after cleaning.

Inside:

When required by the operating conditions, dismantle by removing screws 1.014 and screws 2.074E or nuts 2.074Z and screws 4.066 (if fitted) from cover 2.030. Do not lose nuts 4.061; they will be required for reassembly. Remove and clean cover 2.030. In the case of the single-stage design, clean impeller 2.027 and housing 2.002 after carefully covering rolling-contact bearing 1.007. In the two-stage design, also remove compressor cowl 2.087 (if fitted) after releasing clip 2.129. Remove rolling-contact bearing 1.007 and remove and clean outer impeller 2.027. Remove screws 4.066 on centre section 2.072. Do not lose nuts 4.061; they will be required for reassembly. Remove and clean centre section 2.072.

Clean second impeller 2.027 and housing 2.002.

Reassemble in the reverse order. For reassembling, screw a headless screw temporarily into bearing cover 1.010. Fit cover 2.030 so that the headless screw passes through one of the retaining screw holes, thereby lining them up with the tapped holes in bearing cover 1.010. Insert screws 1.014.

3.2 Lubrication

The following applies in connection with normal operating conditions (gas intake and ambient temperatures 40°C max. and permissible total differential pressure): After approximately 20,000 hours of operation (in the case of 2BH15.. and 2BH16.., refer to deviations given in Fig. 1.3 and Fig. 1.4), or after two and a half years at the latest, the rolling-contact bearings and adjacent spaces should have the spent grease removed and be

recharged with fresh grease. About 50% of the free space in the rolling-contact bearings and about 65% of the adjacent grease spaces should be filled with grease.

Closed rolling-contact bearings should be replaced with new ones (s. Fig. 6); their adjacent grease spaces are not filled with grease.

Type of grease: UNIREX N3 (ESSO); Substitute greases must satisfy DIN 51825-K3N.

The information given concerning bearing life and grease useful life applies to UNIREX N3 only.

Always avoid mixing different types of grease.

3.3 Trouble-shooting (see Fig. 4)

3.4 Note concerning the maintenance instruction

Besides these Instructions, a **Maintenance Instruction** (German-English) is also available that contains notes for qualified personnel (please refer to DIN VDE 0105 or IEC 364 for a definition of qualified personnel) concerning safety, dismantling and assembly of ELMO-G vacuum pumps/compressors of types 2B1 3.. to 2BH1 6..

The **Maintenance Instruction** is available from the manufacturer, provided full details of the sender are given.

4 ELMO-G with EEx e motors

*DIN EN 50014/VDE 0170/0171/1 Part 1 and
DIN EN 50019/VDE 0170/0171/1 Part 6*



The supplementary or special information in italics applies to these machines. When installed in a vertical axial position, an appropriate cover is to be fitted to prevent foreign matter from falling into the motor fan cowl (see DIN EN 50014/VDE 0170/071 Part, Section III, 16.1). This cover must not prevent the motor fan from serving its function.

The temperature class of the motor given on the rating plate must correspond to the temperature class of the combustible class likely to be present. Every machine must be supplied via a motor protection circuit-breaker which is to be set to the rated motor current and which with locked rotor must trip within the time t_{tr} indicated on the rating plate (tested with the aid of the tripping characteristic accompanying the motor protection circuit-breaker). In the case of delta connection, overload protection with phase-failure protection must be provided.

But is overload protection takes the form of a direct temperature monitoring device aided by temperature sensors (see DIN EN 50019/VDE 0170/0171 Part 6, Appendix A-A1.b), the machine must be individually tested and certified as being of suitable design for such protection.

Attention is drawn to DIN 57165/VDE 1065.

Repairs must be done either by a Siemens workshop or an officially recognized expert.

| 2BH13.. - 2BH14.. 50 Hz Vacuum pump/ Compressor | | Zulässige Gesamtdruckdifferenz | | | | Motorbemes- sungsleistung Rated motor output Puissance nomi- nale du moteur Potencia nominal del motor Potenza di tar- atura del motore Motorns- märkeffekt [kW] | Erwärmung ^{c)} Temperature rise ^{c)} Echauffe- ment ^{c)} Calenta- miento ^{c)} Riscald- amento ^{c)} Uppvärm- ning ^{c)} ΔT [K] | Meßflächenschall- druckpegel ^{e)} Measuring-surface sound- pressure level ^{e)} Niveau de pression acoustique ^{e)} Nivel de intensidad acústica en la superficie ^{e)} Livello di pressione acustica delle superfici di misura ^{e)} Ljudtrycksnivå ^{e)} [dB (A)] | Gewicht Weight Poids Peso Peso Vikt [kg] |
|--|---------------------|---|--------------------|---|--------------------|--|---|---|--|
| | | Permissible total differential pressure | | | | | | | |
| | | Pression différentielle admissible | | | | | | | |
| /Type | | Diferencia total admisible de la presión | | | | | | | |
| | | Pressione differenziale totale ammissibile | | | | | | | |
| | | Tillåten total tryckdifferens | | | | | | | |
| | | [bar] | | | | | | | |
| | | Vakuumpumpe ^{b)} Vacuum pump ^{b)} Pompe à vide ^{b)} Bomba de vacío ^{b)} Pompa a vuoto ^{b)} Vakuumpump ^{b)} | | Kompressor ^{b)} Compressor ^{b)} Compresseur ^{b)} Compresor ^{b)} Compressore ^{b)} Kompressor ^{b)} | | Umgebungstemperatur/Ambient temperature Température ambiante/Temperatur ambiente Temperatura ambiente/Omgivningstemperatur | | | |
| | | + 25°C | + 40°C | + 25°C | + 40°C | ca. | | ca. | |
| Einstufige Ausführung Single-stage design Version monostagée Modelo de una etapa Esecuzione ad uno stadio Enstags-utförande | 2BH1300 -1 . C 0 . | 0,10 ^{a)} | 0,10 ^{a)} | 0,11 | 0,10 | 0,25 | 32 | 58 | 8 |
| | -1 . C 1 . | 0,12 ^{a)} | 0,12 ^{a)} | 0,13 ^{a)} | 0,13 ^{a)} | 0,40 | 32 | 58 | 10 |
| | -1 . . 2 . EEx e II | - | 0,11 | - | 0,13 | 0,36 | 32 | 58 | 10 |
| Zweistufige Ausführung Two-stage design Version à 2 étages Modelo de dos etapas Esecuzione a due stadi Tvåstags-utförande | 2BH1310 -1 . C 2 . | 0,205 | 0,18 | 0,24 | 0,20 | 0,77 | 50 | 60 | 14 |
| | -1 . C 4 . | 0,22 | 0,19 | 0,27 | 0,23 | 1,10 | 60 | 60 | 17 |
| | -1 . . 4 . EEx e II | - | 0,19 | - | 0,25 | 0,71 | 55 | 60 | 18 |
| Einstufige Ausführung Single-stage design Version monostagée Modelo de una etapa Esecuzione ad uno stadio Enstags-utförande | 2BH1400 -1 . C 0 . | 0,14 | 0,12 | 0,14 | 0,11 | 0,76 | 37 | 63 | 13 |
| | -1 . C 1 . | 0,165 | 0,15 | 0,18 | 0,15 | 0,90 | 54 | 63 | 14 |
| | -1 . H 2 . | 0,175 | 0,16 | 0,20 | 0,19 | 1,10 | 65 | 63 | 16 |
| | -1 . . 2 . EEx e II | - | 0,17 | - | 0,20 | 1,00 | 66 | 63 | 16 |
| Zweistufige Ausführung Two-stage design Version à 2 étages Modelo de dos etapas Esecuzione a due stadi Tvåstags-utförande | 2BH1410 -1 . C 3 . | 0,28 | 0,25 | 0,325 | 0,25 | 1,75 | 68 | 66 | 24 |
| | -1 . C 4 . | 0,28 | 0,28 | 0,37 | 0,36 | 2,20 | 83 | 66 | 27 |
| | -1 . . 4 . EEx e II | - | 0,28 | - | 0,30 | 1,60 | 60 | 66 | 27 |

a) Fullthrottling is permissible for a short period

c) Temperature rise of housing and air outlet as against ambient temperature during operation at the permissible total pressure difference and at an air pressure of 1013 mbar; this temperature rise increases at lower pressures.

b) **Vacuum pump:** Air extraction at 15°C intake temperature and 1013 mbar discharge pressure
 b) **Compressor:** Air compression at 15°C intake temperature and 1013 mbar intake pressure

Fig. 1.1 2BH13.. - 2BH14.. 50 Hz

| 2BH13.. - 2BH14.. 60 Hz Vacuum pump/ Compressor | Zulässige Gesamtdruckdifferenz Pressione differenziale totale ammissibile Pression différentielle admissible Diferencia total admisible de la presión Permissible total differential pressure Tillåten total tryckdifferens [bar] | Motorbemes- sungsleistung Rated motor output Puissance nomi- nale du moteur Potencia nominal del motor Potenza di tar- atura del motore Motorns märkeffekt [kW] | | | | Erwärmung ^{c)} Temperature rise ^{c)} Echauffe- ment ^{c)} Calenta- miento ^{c)} Riscald- amento ^{c)} Uppvärm- ning ^{c)} ΔT [K] | Meßflächenschall- druckpegel ^{e)} Measuring-surface sound- pressure level ^{e)} Niveau de pression acoustique ^{e)} Nivel de intensidad acústica en la superficie ^{e)} Livello di pressione acustica delle superfici di misura ^{e)} Ljudtrycksnivå ^{e)} [dB (A)] | Gewicht Weight Poids Peso Peso Vikt [kg] | |
|--|---|---|--------------------|---|------|---|---|--|----|
| | | Vakuumpumpe ^{b)} Vacuum pump ^{b)} Pompe à vide ^{b)} Bomba de vacío ^{b)} Pompa a vuoto ^{b)} Vakuumpump ^{b)} | | Kompressor ^{b)} Compressor ^{b)} Compresseur ^{b)} Compresor ^{b)} Compressore ^{b)} Kompressor ^{b)} | | | | | |
| | | Umgebungstemperatur/Ambient temperature Température ambiante/ Temperatura ambiente Temperatura ambiente/Omgivningstemperatur | | | | | | | |
| /Type/ | + 25°C | + 40°C | + 25°C | + 40°C | ca. | ca. | ca. | | |
| Einstufige Ausführung Single-stage design Version monostagée Modelo de una etapa Esecuzione ad uno stadio Enstegs-utförande | 2BH1300 -1 . C 0 . | 0,11 | 0,10 | 0,11 | 0,10 | 0,29 | 25 | 61 | 8 |
| | -1 . C 1 . | 0,15 ^{a)} | 0,15 ^{a)} | 0,17 | 0,14 | 0,50 | 60 | 61 | 10 |
| | -1 . . 2 . EEx e II | - | 0,15 | - | 0,15 | 0,53 | 40 | 61 | 10 |
| Zweistufige Ausführung Two-stage design Version à 2 étages Modelo de dos etapas Esecuzione a due stadi Tvåstegs-utförande | 2BH1310 -1 . C 2 . | 0,25 | 0,20 | 0,25 | 0,20 | 0,89 | 60 | 66 | 14 |
| | -1 . C 4 . | 0,28 | 0,24 | 0,34 | 0,28 | 1,3 | 80 | 66 | 17 |
| | -1 . . 4 . EEx e II | - | - | - | - | - | - | - | 18 |
| Einstufige Ausführung Single-stage design Version monostagée Modelo de una etapa Esecuzione ad uno stadio Enstegs-utförande | 2BH1400 -1 . C 0 . | 0,135 | 0,11 | 0,135 | 0,10 | 0,93 | 30 | 64 | 13 |
| | -1 . C 1 . | 0,18 | 0,15 | 0,18 | 0,14 | 1,15 | 50 | 64 | 14 |
| | -1 . H 2 . | 0,21 | 0,19 | 0,23 | 0,21 | 1,50 | 75 | 64 | 16 |
| | -1 . . 2 . EEx e II | - | 0,20 | - | 0,20 | 1,25 | 63 | 64 | 16 |
| Zweistufige Ausführung Two-stage design Version à 2 étages Modelo de dos etapas Esecuzione a due stadi Tvåstegs-utförande | 2BH1410 -1 . C 3 . | 0,325 | 0,24 | 0,315 | 0,23 | 2,15 | 65 | 69 | 24 |
| | -1 . C 4 . | 0,35 | 0,34 | 0,43 | 0,39 | 2,55 | 82 | 69 | 27 |
| | -1 . . 4 . EEx e II | - | 0,30 | - | 0,30 | 2,00 | 65 | 69 | 27 |

d) Lubrication intervals in hours of operation (deviating from the general recommendation of 20 000)

e) Measuring-surface sound-pressure level (DIN 45 635 Part 13) measured at a distance of 1 m and at an operating point of about 2/3 of the permissible total differential pressure, with hoses attached, but without vacuum or pressure limiting valve

Fig. 1.2 2BH13.. - 2BH14.. 60 Hz

| 2BH15.. - 2BH16.. 60 Hz Vacuum pump/ Compressor | Zulässige Gesamtdruckdifferenz | | | | Motorbemes- sungsleistung Rated motor output Puissance nomi- nale du moteur Potencia nominal del motor Potenza di tar- atura del motore Motor- märkeffekt [kW] | Erwärmung ^{c)} Temperature rise ^{c)} Echauffe- ment ^{c)} Calenta- miento ^{c)} Riscald- amento ^{c)} Uppvärm- ning ^{c)} ΔT [K] | Meßflächenschall- druckpegel ^{e)} Measuring-surface sound- pressure level ^{e)} Niveau de pression acoustique ^{e)} Nivel de intensidad acústica en la superficie ^{e)} Livello di pressione acustica delle superfici di misura ^{e)} Ljudtrycksnivå ^{e)} [dB (A)] | Gewicht Weight Poids Peso Peso Vikt [kg] | |
|--|---|-------------------|-------------------|--|--|---|---|--|----|
| | Pressione differenziale totale ammissibile | | | | | | | | |
| | Pression différentielle admissible | | | | | | | | |
| Diferencia total admisible de la presión | | | | Permissible total differential pressure | | | | | |
| Tillåten total tryckdifferens | | | | [bar] | | | | | |
| Vakuumpumpe ^{b)} Kompressor ^{b)} Vacuum pump ^{b)} Compressor ^{b)} Pompe à vide ^{b)} Compresseur ^{b)} Bomba de vacío ^{b)} Compresor ^{b)} Pompa a vuoto ^{b)} Compressore ^{b)} Vakuumpump ^{b)} Kompressor ^{b)} | | | | | | | | | |
| Umgebungstemperatur/Ambient temperature | | | | Température ambiante/Temperatur ambiente | | | | | |
| Temperatura ambiente/Omgivningstemperatur | | | | | | | | | |
| Typ/Type/Tipo | + 25°C | + 40°C | + 25°C | + 40°C | | ca. | ca. | ca. | |
| Einstufige Ausführung Single-stage design Version monoétage Modelo de una etapa Esecuzione ad uno stadio Enstegs-utförande | 2BH1500 -1 . C 0 . | 0,12 | 0,11 | 0,11 | 0,10 | 0,86 | 22 | 73 | 18 |
| | -1 . C 1 . | 0,17 | 0,16 | 0,16 | 0,15 | 1,3 | 36 | 73 | 20 |
| | -1 . C 2 . | 0,20 | 0,20 | 0,20 | 0,20 | 1,75 | 50 | 73 | 21 |
| | -1 . C 3 . | 0,26 | 0,25 | 0,30 | 0,29 | 2,55 | 82 | 73 | 24 |
| | -1 .. 3 . EEx e II | - | 0,20 | - | 0,19 | 1,95 | 52 | 73 | 24 |
| Zweistufige Ausführung Two-stage design Version à 2 étages Modelo de dos etapas Esecuzione a due stadi Tvåstegs-utförande | 2BH1510 -1 . C 4 . | 0,41 7 000 d) | 0,38 10 000 d) | 0,42 | 0,42 | 3,45 | 80 | 77 | 38 |
| | -1 . C 5 . | 0,42 11 000 d) | 0,40 14 000 d) | 0,53 14 000 d) | 0,45 | 4,6 | 94 | 77 | 55 |
| | -1 .. 5 . EEx e II | - | 0,40 14 000 d) | - | 0,32 | 3,50/3,40 | 90 | 77 | 55 |
| Einstufige Ausführung Single-stage design Version monoétage Modelo de una etapa Esecuzione ad uno stadio Enstegs-utförande | 2BH1600 -1 . C 0 . | 0,12 | 0,11 | 0,11 | 0,11 | 1,73 | 20 | 75 | 26 |
| | -1 . C 1 . | 0,22 | 0,21 | 0,20 | 0,18 | 2,55 | 40 | 76 | 29 |
| | -1 . C 2 . | 0,28 | 0,27 | 0,27 | 0,25 | 3,45 | 80 | 76 | 34 |
| | -1 . C 3 . | 0,32 | 0,29 | 0,33 | 0,30 | 4,6 | 85 | 76 | 49 |
| | -1 .. 3 . EEx e II | - | 0,26 | - | - | 3,80 | 75 | 76 | 49 |
| Zweistufige Ausführung Two-stage design Version à 2 étages Modelo de dos etapas Esecuzione a due stadi Tvåstegs-utförande | 2BH1610 -1HC 1 . | 0,20 | 0,18 | 0,15 | 0,13 | 2,55 | 30 | 79 | 42 |
| | -1HC 2 . | 0,27 | 0,25 | 0,22 | 0,20 | 3,45 | 48 | 79 | 46 |
| | -1HC 3 . | 0,38 | 0,37 | 0,35 | 0,34 | 4,6 | 75 | 79 | 52 |
| | -1HC 4 . | 0,43 | 0,40 15 000 d) | 0,53 | 0,48 | 6,3 | 88 | 79 | 70 |
| | -1HC 5 . | 0,45 | 0,40 15 000 d) | 0,68 | 0,53 | 8,6 | 130 | 79 | 77 |
| | -1H . 5 . EEx e II | - | 0,40 15 000 d) | - | 0,54 | 5,80/7,70 | 90 | 79 | 86 |
| Zweiflutige Ausführung Double-flow design Version à deux étages Modelo de dos etapas Esecuzione a due stadi Tvåstegs-utförande, parallellkopplad | 2BH1640 -1GC 3 . | - | - | - | - | - | - | - | - |
| | -1GC 4 . | 0,18 | 0,18 | 0,17 | 0,17 | 6,3 | 30 | 80 | 73 |
| | -1GC 5 . | 0,26 | 0,26 | 0,26 | 0,26 | 8,6 | 42 | 80 | 86 |
| | -1G . 5 . | - | 0,21 | - | 0,23 | 6,50/7,80 | 34 | 80 | 86 |

Fig. 1.4 2BH15.. - 2BH16.. 60 Hz

ENGLISH

Spare parts (Fig. 2), available from the works (see order example)

| | |
|-------|-----------------------------|
| 1.010 | Bearing cover, complete |
| 1.033 | O-ring seal |
| 1.078 | Disc |
| 2.002 | Compressor housing |
| 2.027 | Impeller |
| 2.030 | Compressor cover |
| 2.072 | Centre section |
| 2.073 | Threaded rod |
| 2.087 | Compressor cowl |
| 2.127 | Disc |
| 2.129 | Clip |
| 2.134 | Sleeve |
| 2.135 | Locking hook |
| 3.005 | Motor rotor |
| 3.095 | Felt ring |
| 3.096 | Shaft sealing ring |
| 4.001 | Stator, complete |
| 4.011 | Spiral pin |
| 4.040 | Rating plate |
| 4.041 | Screw |
| 4.044 | Cover |
| 4.062 | Foot |
| 4.065 | Sleeve |
| 4.080 | Screw |
| 4.082 | Earthing bracket |
| 4.083 | Contact bracket |
| 6.009 | Disc |
| 6.018 | Resilient preloading ring |
| 6.450 | Endshield |
| 6.455 | Spring strip |
| 7.039 | Tolerance ring |
| 7.500 | Fan cowl |
| 7.501 | External fan |
| 7.503 | Screw |
| 7.505 | Featherkey for external fan |
| 8.034 | Flange |
| 8.035 | Flange |
| 8.037 | Plug |
| 8.048 | Graded tube, intake side |
| 8.049 | Graded tube, discharge side |
| 8.054 | Gasket |
| 8.055 | Gasket |
| 8.130 | Filler |
| 8.131 | Setscrew |
| 8.132 | Filler |
| 8.156 | Filler |
| 8.403 | Silencer casing |
| 8.413 | Silencer insert |
| 8.433 | Gasket |
| 8.446 | Threaded rod |
| 8.990 | Silencer, complete |

Order example

2BH1 300 - 1AC 12
No E F2 7 45688 70 010 /95
LaufRad 2.027

Normteile sind nach Abmessung, Werkstoff und Oberfläche im freien Handel zu beziehen.

Standard commercially available parts are to be purchased in accordance with the specified dimensions, material and surface finish.

Les pièces normalisées peuvent être obtenues dans le commerce d'après leurs dimensions, le matériau et l'état de surface.

Las piezas estándar se comprarán en comercios del ramo según las dimensiones, material y superficie especificados. Le parti standard sono reperibili sul mercato secondo le dimensioni, il materiale e la finitura della superficie.

Normerade detaljer kan erhållas i öppna handeln, och skall specificeras beträffande storlek, material och ytbehandling.

| | | |
|--------|----------|----------|
| 1.014 | DIN 84 | DIN 933 |
| 1.029 | | |
| 2.025 | | |
| 2.074E | | |
| 2.089 | DIN 965 | DIN 6912 |
| 4.063 | | |
| 4.066 | | |
| 6.451 | | |
| 8.053 | | |
| 8.098 | | |
| 8.142 | DIN 7985 | |
| 8.444 | | |

| | | |
|-------|-------|---------|
| 1.069 | 4.064 | DIN 128 |
| 2.024 | 4.067 | |
| 2.128 | 4.081 | |

| | |
|-------|---------|
| 7.506 | DIN 471 |
|-------|---------|

| | |
|-------|---------|
| 4.070 | DIN 557 |
|-------|---------|

| | |
|-------|---------|
| 4.061 | DIN 562 |
|-------|---------|

| | |
|-------|---------|
| 2.058 | DIN 580 |
|-------|---------|

| | |
|-------|---------|
| 8.476 | DIN 917 |
|-------|---------|

| | | |
|--------|-------|---------|
| 2.074Z | 6.458 | DIN 934 |
| 2.090 | 8.038 | |
| 4.172 | 8.466 | |

| | |
|-------|----------|
| 3.006 | DIN 6885 |
|-------|----------|

| | |
|-------|----------|
| 1.012 | DIN 9021 |
|-------|----------|

| | | |
|-------|--------------------|---|
| 1.007 | Lagertyp: DIN 625 |  |
| 6.008 | Type of bearing | |
| | Type de roulement | |
| | Tipo de rodamiento | |
| | Tipo di cuscinetto | |
| | Lagertyp | |

2BH1 3..
2BH1 4..
2BH1 5..
2BH1 6..

Einstufige Ausführung
Single-stage design
Version mono-étagée
Modelo de una etapa
Esecuzione ad uno stadio
Enstegs-utförande

Zweistufige Ausführung
Two-stage design
Version à 2 étages
Modelo de dos etapas
Esecuzione a due stadi
Tvåstegs-utförande

Fig. 2

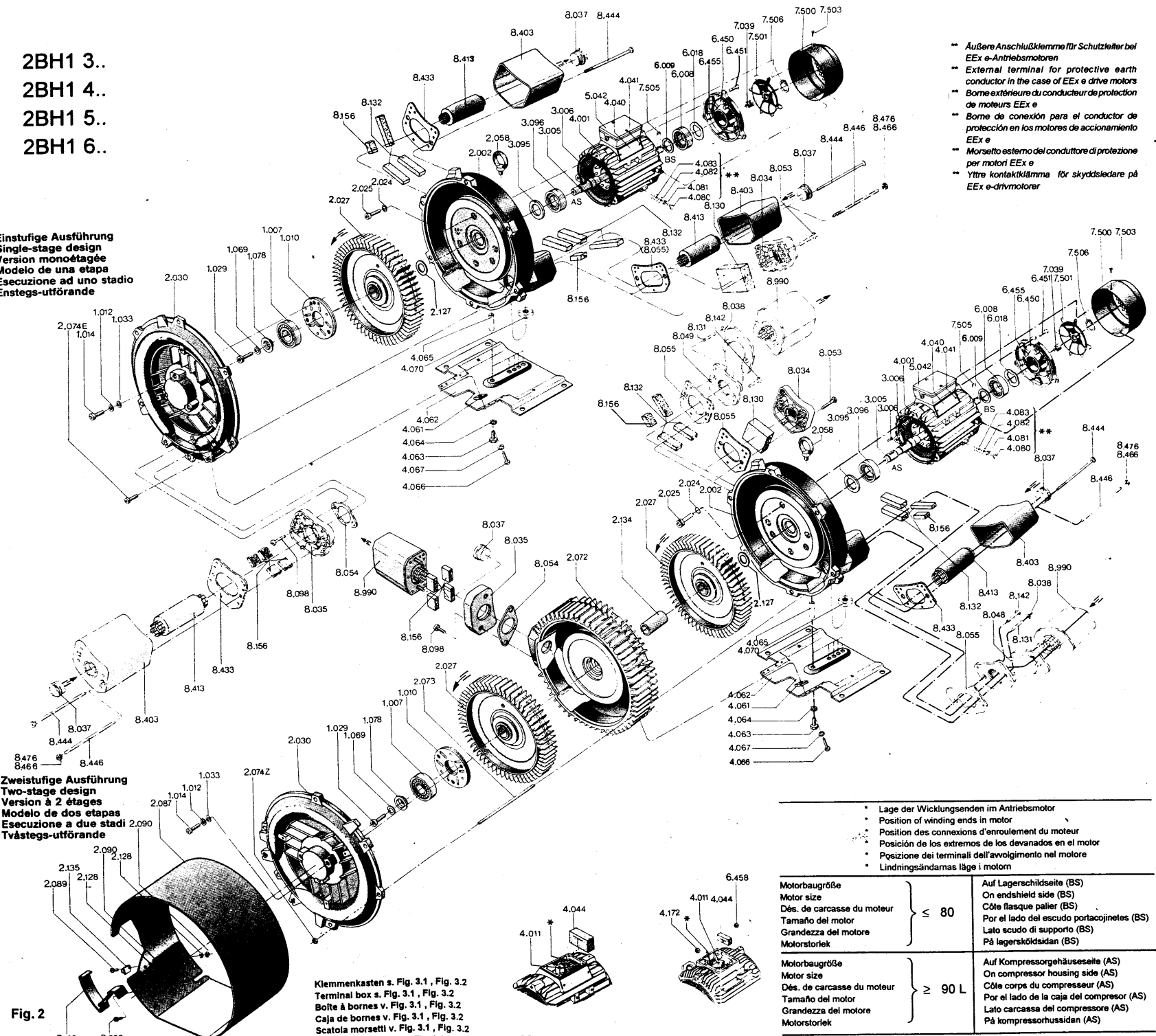

- **Außere Anschlussklemme für Schutzleiter bei EEx e-Antriebsmotoren**
- **External terminal for protective earth conductor in the case of EEx e drive motors**
- **Borne extérieure du conducteur de protection de moteurs EEx e**
- **Borne de conexión para el conductor de protección en los motores de accionamiento EEx e**
- **Morsetto esterno del conduttore di protezione per motori EEx e**
- **Yttre kontaktklämma för skyddsledare på EEx e-drivmotorer**

Klemmenkasten s. Fig. 3.1, Fig. 3.2
Terminal box s. Fig. 3.1, Fig. 3.2
Boîte à bornes v. Fig. 3.1, Fig. 3.2
Caja de bornes v. Fig. 3.1, Fig. 3.2
Scatola morsetti v. Fig. 3.1, Fig. 3.2
Uttagsslåda s. Fig. 3.1, Fig. 3.2

- Lage der Wicklungsenden im Antriebsmotor
- Position of winding ends in motor
- Position des connexions d'enroulement du moteur
- Posición de los extremos de los devanados en el motor
- Posizione dei terminali dell'avvolgimento nel motore
- Lindningsändansans läge i motorn

| | | |
|---|--------|---|
| Motorbaugröße Motor size Dés. de carcasse du moteur Tamaño del motor Grandezza del motore Motorstorlek | } ≤ 80 | Auf Lagerschildseite (BS) On endshield side (BS) Côté flasque palier (BS) Por el lado del escudo portacojinetes (BS) Lato scudo di supporto (BS) På lagersköldsidan (BS) |
| Motorbaugröße Motor size Dés. de carcasse du moteur Tamaño del motor Grandezza del motore Motorstorlek | | } ≥ 90 L |

Klemmenkasten in Normalausführung
Terminal box in standard design
Boîte à bornes en exécution normale
Caja de bornes en ejecución normal
Scatola morsetti in esecuzione normale
Uttagsslåda in normalt utförande

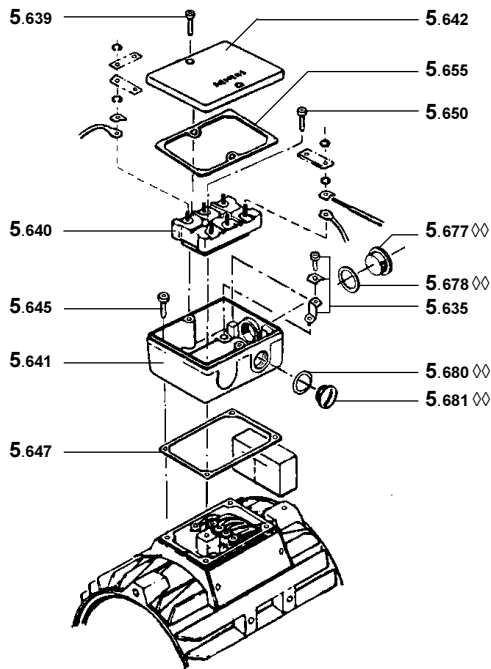

◇◇ Use only parts of electrically non-conductive material.

Klemmenkasten in EEx e-Ausführung
Terminal box in EEx e design
Boîte à bornes en exécution EEx e
Caja de bornes de la ejecución EEx e
Scatola morsetti in esecuzione EEx e
Uttagsslåda i explosionskyddat utförande EEx e

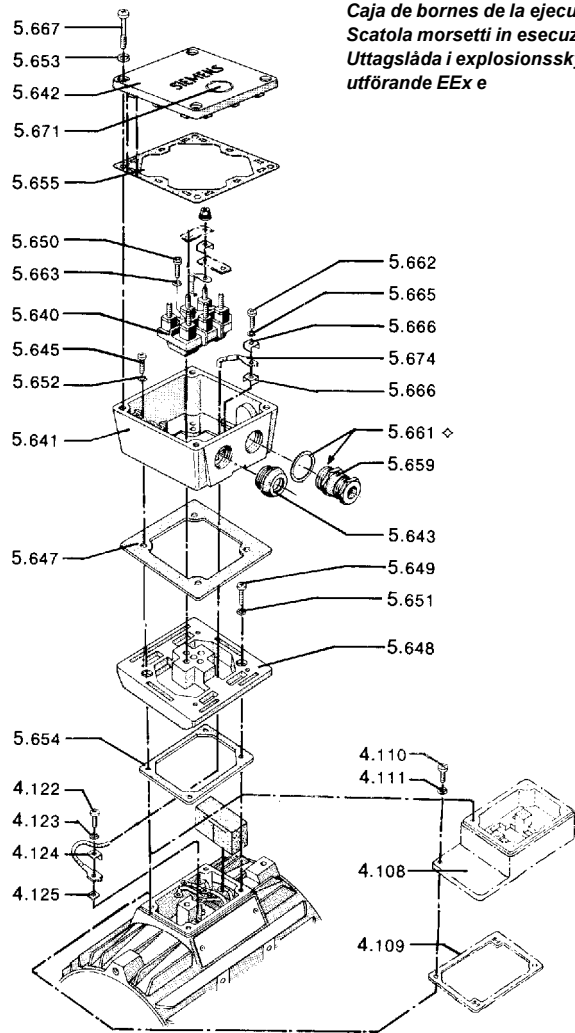

◇ Alternatively use Teflon tape for thread

Fig. 3.1

Terminal box for motors of frame sizes $\leq 90L$ (Top section of terminal box shown rotated through 180°)

i
Standard commercially available parts are to be purchased in accordance with the specified dimensions, material and surface finish.

4.111 5.653
4.123 5.663
5.651 5.665
5.652 5.673



4.110 DIN 7981

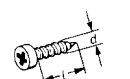

5.650 DIN 7985
5.672

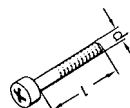

5.661 ◇
5.678 ◇◇
5.680 ◇◇

DIN 46320



5.677 ◇◇
5.681 ◇◇

DIN 46320
Bl. 4



5.659 DIN 46320
Bl. 4



Terminal box in standard design

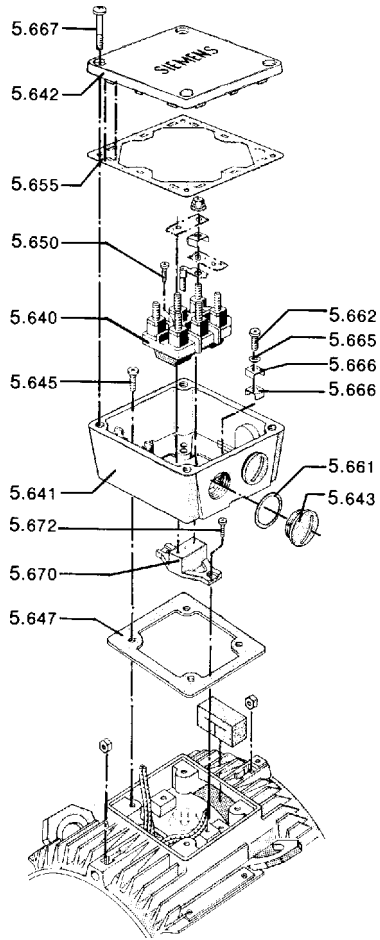

Terminal box in EEx e design

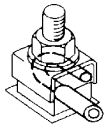
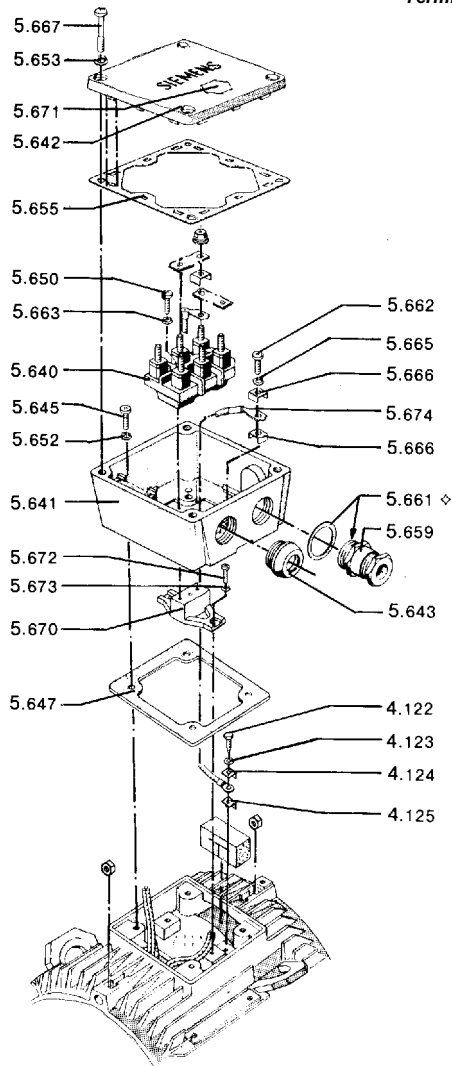

Connecting a single conductor with a terminal clip.

Fig. 3.2

Terminal box for motors of frame sizes $\geq 100L$ (Top section of terminal box shown rotated through 180°)

| | | |
|--|--|--|
| | | |
| | | |
| | | |
| | | |
| | | |
| | | |
| | | |
| | | |

ENGLISH

| Fault | Cause | Remedy |
|---|--|---|
| Motor does not start, no rotor noise | At least two power supply conductors interrupted | Eliminate interruption by means of fuses, terminals or feeder leads |
| Motor does not start, humming noise | Interruption in one power supply conductor; impeller jammed Impeller defective Motor bearing defective | See "Motor does not start, no running noise"; open cover, remove foreign matter, clean; if necessary check impeller gap adjustment and correct if necessary. Fit new impeller Fit new bearing |
| Motor protective circuit-breaker trips again after motor is switched on, power consumption too high | Short-circuit in the winding Motor overloaded Compressor jammed | Arrange for winding to be inspected Reduce operating pressure, clean filter, silencer, connecting pipes if necessary See "Motor does not start, humming noise" |
| No vacuum or too weak a vacuum is produced | Leak in the system, wrong direction of rotation Wrong frequency Compressor too small Shaft seal defective Varying density of delivery gas Change of blade profile due to fouling | Make system air-tight; Change direction of rotation (changeover to electrical supply leads); correct frequency; use larger compressor; fit new shaft seal; pay attention to conversion of pressure values; Clean impeller, replace worn impeller with a new one |
| Abnormal squeaking noises | Too high a flow rate; Silencer dirty Ball bearing lacks grease or is defective | Increase pipe cross-section, clean; clean silencer inserts, fit new ones if necessary; regrease ball bearing or fit new one |
| Compressor not air-tight | Gaskets defective | Inspect gaskets |

Fig. 4 **Trouble-shooting**