



VACUUM VALVES



Introduction

Isolation and tightness

Certain functionalities are necessary for vacuum technology:

- **Connections:** The majority of vacuum systems require connections with either pumping systems or different peripheral accessories.
- **Tightness:** It is often necessary that connections are perfectly tight when closed in order to preserve vacuum integrity, while still allowing servicing.
- **Specific parameters:** Different vacuum applications will have different needs, with stringent requirements regarding: materials, dimensions,... These parameters must be considered in order to select the best vacuum valve solution for the specific application.

Vacuum valves: the Alcatel offer

Alcatel supplies customers with complete pumping systems that combine pumps with top-quality accessories, including vacuum valves. The new Adixen range of vacuum valves has been created in cooperation with VAT, world leader in vacuum valves and sealing technology.

A number of products presented in this section of the catalogue are designed and manufactured by VAT for Alcatel. This partnership helps to ensure that we offer our customers the best vacuum components available on the market.



A broad range

Alcatel offers a solution for each application.

- **Variations by type:** Each type of valve (Gate, Butterfly, Angle...) is available in different versions, offering different materials, flanges, actuators, etc..., to provide the most appropriate solution to any of a wide range of demands.
- **Special valves:** A variety of special vacuum valves (vent valves, 3 way valves, leak valves, throttling valves...) complements the Alcatel offer.

Common specifications

All vacuum valves have the following common specifications:

- Guaranteed tightness
- Individually tested
- Standard flanges
- High conductance
- High reliability
- Operation in all positions



Gate valves

▶ p C25.05

Gate valves allow a 100 % open position and thus a maximum conductance.

In the open position, the mechanism (gate and counter plate) is completely inserted in the body; no obstacle will modify the gas flow.

- Compact and low profile, they can be easily integrated into equipment in any position.

- The locking device, designed with unlubricated balls, allows minimal closing shock and minimal wear, preventing seat seal damage when closing and opening.
- UHV gate valves (stainless steel body) have a bellow sealed shaft feedthrough and metal seal between body and bon-net. Vacuum gate valves (Aluminium

body) have FPM seals for shaft feedthrough and bonnet.

- Models with pneumatic actuators are closed in case of power failure. They stay mechanically locked even with compressed air failure.

Butterfly valves

▶ p C25.13

- Butterfly valves can be a compact and economic alternative for gate valves. Based on a rugged and simple design, they consist of a circular plate rotating into the valve body.
- Models DN 63 to DN 200 have a unique plate actuating mechanism. The plate first swings to the closed position without any friction from

the plate seal. The sealing procedure is similar to that of a gate valve, with a linear movement (driven by the patented spiral mechanism). Only for applications in clean vacuum systems because of exposed plate seal.

- Available with stainless steel body (CF-F flanges) and aluminium body (ISO-F flanges) they have a bellow sealed shaft

feedthrough.

- Models with pneumatic actuators are delivered with position indicator and solenoid.
- Models DN 40 and DN 50 (manual actuators) are suitable for numerous applications: accessory isolation, venting...

Angle valves

▶ p C25.19

- The angle valve range is characterized by its variety of models and its actuating principles.
- Manual, pneumatic and electromagnetic angle valves are among the most used in all applications of vacuum technology.

- The choice of materials, of different tightness designs and levels, make it possible to find suitable solutions for the majority of requirements:
 - pumping systems
 - connection between pumps
 - pure gas
 - corrosive gas

- medium vacuum
- high vacuum
- ultra-high vacuum

- From DN 16 to DN 250, the broad range of angle valve configurations lets users select the best compromise between cost and performances.

Special valves

▶ p C25.31

As a complement to its range of Gate, Butterfly and Angle valves, Alcatel offers a line of special vacuum valves for specific demands.

- Isolation valves for medium vacuum and high pressure (gas and fluids)
 - diaphragm valves DN 16-25-40

- ball valves DN 16-40 (2 ways - 3 ways)
- Micro flow regulation valves DN 16
- Leak valves DN 16
- Vent valves DN 16
- Safety Isolation Valves for rotary vane pumps DN 16-25

Other models

For applications that require valves other than those listed above, Alcatel will be pleased to advise suitable solutions.

Vacuum valves:

All valves with pneumatic actuators are delivered with position indicators and solenoids.

Gate valve	UHV	S.S.	DN 63 to 250	manual or pneumatic
	HV	alu	DN 16 to 250	manual or pneumatic
Butterfly valve	UHV	S.S.	DN 63 to 200	pneumatic
	HV	alu	DN 63 to 200	pneumatic
Angle valve	UHV	S.S.	DN 16 - 40 - 63	manual or pneumatic
	HV	alu	DN 25 - 40	electro-magnetic
	HV	alu	DN 16 to 160	manual or pneumatic
	HV	S.S.	DN 16 to 80	manual or pneumatic
	HV	alu	DN 16 to 160	pneumatic

Table of voltages

This table of voltages provides the letters required to complete the codes when ordering some valve models. The letter is to be added to the code number, in order to define the appropriate voltage.

	Direct current	Frequency 50/60 Hz	Frequency 50 Hz	Frequency 60 Hz
12 V	A			
24 V	B	E	J	P
48 V	K	U	S	
100 V		F		
100/115 V		C		
110/115 V		G	L	Q
200 V		H		
200/230 V		D		
220/230 V		I	V	R

Seal kit

For any seals kit of valves not referred in this catalogue, please contact the Alcatel Vacuum Technology Commercial Department.

Seal kit = 1 seal for the plate + 1 seal for the body.

HV Gate valves

DN 16 - 250

Main Specifications	
Aluminium body	
Thin profile and light weight	
High quality shaft feedthrough:	FPM seals
Leak rate, body seat:	$<10^{-9}$ mbar.l/s
Pressure range: DN 16 - 50:	1.10^7 mbar to 1 bar (abs)
DN 63 - 200:	1.10^7 mbar to 1.6 bar (abs)
DN 250:	1.10^7 mbar to 1.2 bar (abs)
Differential pressure on the gate:	
DN 16 - 50:	≤ 1 bar in either direction
DN 63 - 200:	≤ 1.6 bar in either direction
DN 250:	≤ 1.2 bar in either direction
Max differential pressure at opening ≤ 30 mbar	
Cycles until first service: DN 16 - 50:	50 000
DN 63 - 100:	200 000
DN 160 - 250:	100 000
Bake-out temperature:	
• Valve DN 16 - 50	≤ 100 °C
• Valve DN 63 - 250	≤ 120 °C
• Manual and pneumatic actuator	80 °C
• Position indicator	80 °C
• Solenoid	50 °C
Seals:	
• Bonnet	FPM
• Plate	FPM



HV Gate valves DN 16 - 250

(aluminium body, FPM/shaft feedthrough)

Manual and pneumatic actuators

(double acting cylinder, with position indicator and solenoid)

Seal kits (see page C25.04)

For HV gate valves, DN 16 - 250

Manual and pneumatic actuators

Flange DN		PART NUMBER		
mm	inch	ISO-KF	ISO-F	JIS
16	5/8	30381 *		
25	1	30382 *		
40	1 1/2	30383 *		
50	2	30384 *		
63	2 1/2		31024 *	
80	3		31544 *	31545 *
100	4		31025 *	31033 *
160	6		31026 *	31034 *
200	8		31027 *	31035 *
250	10		31028 *	31036 *

Flange DN		PART NUMBER
mm	inch	
16	5/8	30385K
25	1	30386K
40	1 1/2	30387K
50	2	30388K
63	2 1/2	31152K
80	3	31546K
100	4	31153K
160	6	31532K
200	8	31533K
250	10	31534K

* Please indicate the appropriate letter:

- M for manual actuator

- for pneumatic actuator, one of the options A, B, E, F, G, H, I, K, U from voltages table page C25.04.

- DN 200 - DN 250 not available with manual actuator

HV Gate valves DN 16 - 250

Technical data

DN (nom. I. D)		Standard flanges			Molecular flow conductance	Manual		Pneumatic						
		ISO-KF	ISO-F	JIS		Weight		Compressed air pressure min. - max. overpressure		Volume of air cylinder		Closing or opening time	Weight	
mm	inch				l/s	kg	lbs	bar	psig	l	Ft3	s	kg	lbs
16	5/8	16			10	0.4	0.9	4.5 - 7	65 - 100	0.01	.0004	0.8	0.8	1.8
25	1	25			34	0.4	0.9	4.5 - 7	65 - 100	0.03	.0010	0.1	0.8	1.8
40	1 1/2	40			140	0.7	1.5	4.5 - 7	65 - 100	0.07	.0020	1.2	1.2	2.7
50	2	50			260	1.4	3	4.5 - 7	65 - 100	0.07	.0020	1.3	1.2	2.7
63	2 1/2		63	63	550	3	7	4 - 7	55 - 100	0.16	.0060	1.5	3	7
80	3		80	80	1000	3.8	9	4 - 7	55 - 100	0.20	.0007	1.7	3.8	9
100	4		100	100	2000	4.5	10	4 - 7	55 - 100	0.22	.0080	2.0	4.5	10
160	6		160	150	6000	9	20	4 - 7	55 - 100	0.50	.0180	2.0	9	20
200	8		200	200	12000	-	-	4 - 7	55 - 100	0.90	.0320	3.0	18	38
250	10		250	250	22000	-	-	4 - 7	55 - 100	1.50	.0530	5.0	25	55

Dimensions manual actuator

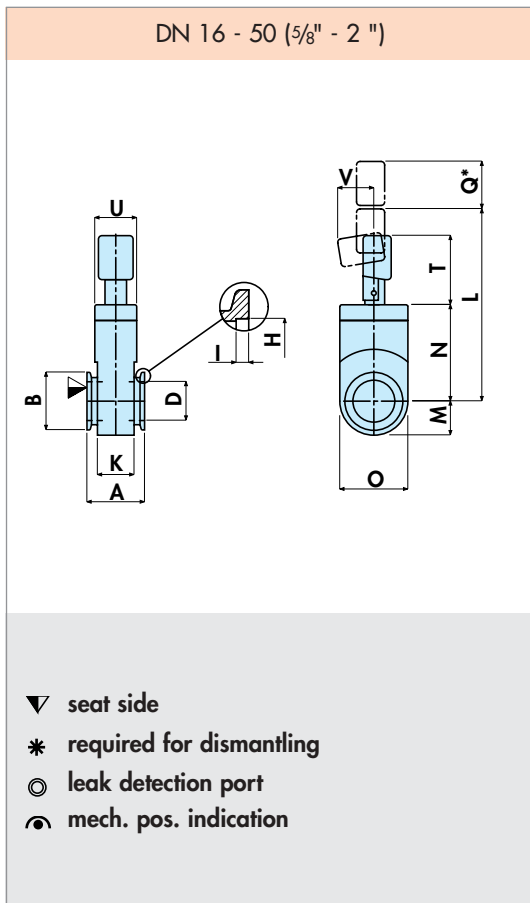

DN	mm inch	16 5/8	25 1	40 1 1/2	50 2
A	mm inch	40 1.57	50 1.97	51 2.01	55 2.17
B	mm inch	30 1.18	40 1.57	55 2.17	75 2.95
D	mm inch	15 .59	24 .94	39 1.54	49 1.93
H	mm inch	17.2 .68	26.2 1.03	41.2 1.62	52.2 2.06
I	mm inch	3 .12	3 .12	3 .12	3 .12
K	mm inch	25 .98	32 1.26	31 1.22	33 1.30
L	mm inch	100 3.94	139 5.47	208 8.19	240 9.45
M	mm inch	15 .59	22 .87	32.5 1.28	37.5 1.48
N	mm inch	39 1.55	59 2.32	93 3.66	108 4.25
O	mm inch	30 1.18	44 1.73	65 2.56	75 2.95
Q	mm inch	28 .98	35 1.38	55 2.17	65 2.56
T	mm inch	37 1.46	50 1.97	85 3.35	93 3.67
U	mm inch	25 .98	32 1.26	40 1.57	40 1.57
V	mm inch	30 1.18	30 1.18	50 1.97	55 2.17

HV Gate Valves

DN 16 - 250

Dimensions manual actuator

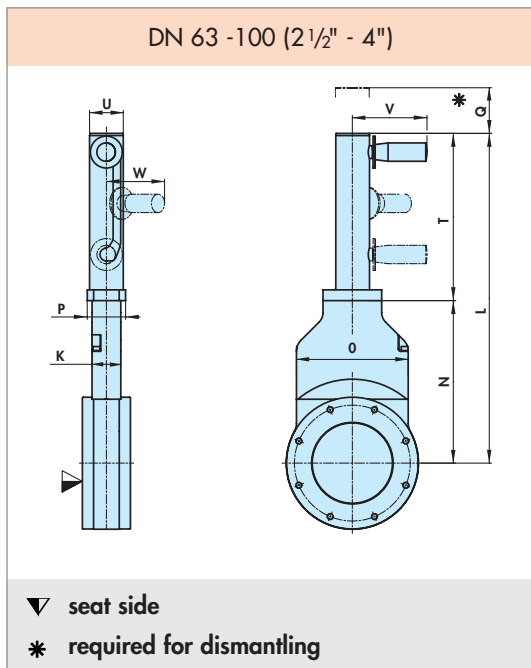

DN	mm inch	63 2½	80 3	100 4
K	mm	36	36	36
	inch	1.42	1.42	1.42
L	mm	329.5	363	413
	inch	12.97	14.29	16.26
N	mm	155.5	173.5	203.5
	inch	6.12	6.83	8.01
O	mm	100	118	140
	inch	3.94	4.65	5.51
P	mm	48	48	48
	inch	1.89	1.89	1.89
Q	mm	25	25	25
	inch	0.98	0.98	0.98
T	mm	174	189.5	209.5
	inch	6.85	7.46	8.25
U	mm	43	43	43
	inch	1.69	1.69	1.69
V	mm	94	94	94
	inch	3.7	3.7	3.7
W	mm	75	75	75
	inch	2.95	2.95	2.95

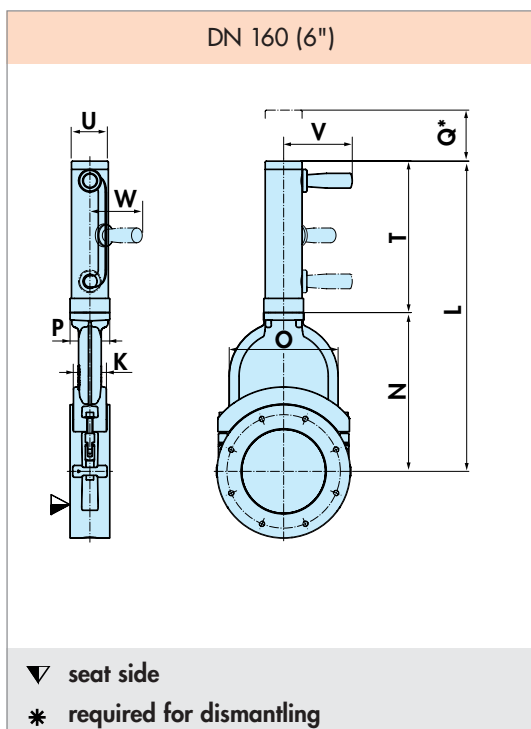

DN	mm inch	160 6
K	mm	58
	inch	2.28
L	mm	547
	inch	21.54
N	mm	280
	inch	11.02
O	mm	192
	inch	7.56
P	mm	70
	inch	2.76
Q	mm	60
	inch	2.36
T	mm	267
	inch	10.51
U	mm	65
	inch	2.56
V	mm	122
	inch	4.8
W	mm	95
	inch	3.74

HV Gate valves

DN 16 - 250

Dimensions pneumatic actuator

DN 16 - 50 (5/8" - 2")

▼ seat side
 * required for dismantling
 Ⓜ mech. pos. indication
 Ⓞ comp. air connection (1/8" NPT for USA)
 Ⓢ electrical connection

DN	mm inch	16 5/8	25 1	40 1 1/2	50 2
A	mm inch	40 1,57	50 1.97	51 2.01	55 2.17
B	mm inch	30 1.18	40 1.57	55 2.17	75 2.95
D	mm inch	15 .59	24 .94	39 1.54	49 1.93
H	mm inch	17.2 .68	26.2 1.03	41.2 1.62	52.2 2.06
I	mm inch	3 .12	3 .12	3 .12	3 .12
K	mm inch	25 .98	32 1.26	31 1.22	33 1.30
L	mm inch	105 4.13	136 5.35	196 7.72	220 8.66
M	mm inch	15 .59	22 .87	32.5 1.28	37.5 1.48
N	mm inch	39 1.55	56 2.20	88 3.46	103 4.06
O	mm inch	30 1.18	44 1.73	65 2,56	75 2.95
Q	mm inch	25 .98	35 1.38	55 2.57	65 2.56
U	mm inch	25 .98	32 1.26	40 1.57	40 1.57
V	mm inch	56 2.20	61 2.40	65 2.56	65 2.56
W	mm inch	55 2.17	60 2.36	61 2.40	66 2.60
W1	mm inch	50 1.97	50 1.97	50 1.97	50 1.97

HV Gate valves

DN 16 - 250

Dimensions pneumatic actuator

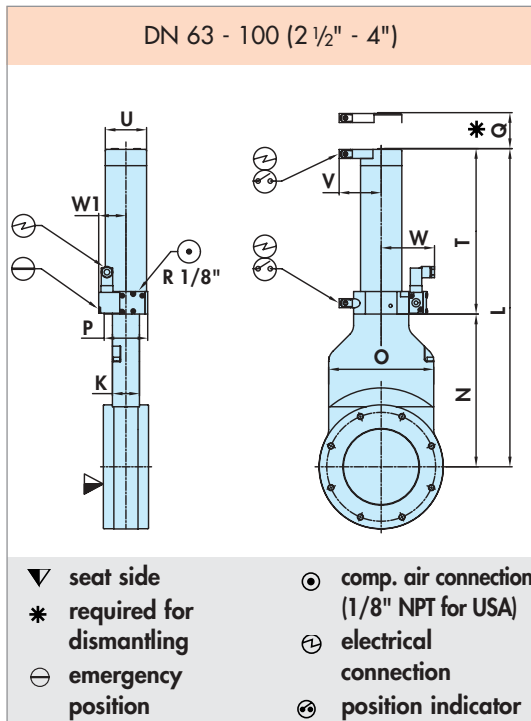

DN	mm inch	63 2 1/2	80 3	100 4
K	mm inch	36 1.42	36 1.42	36 1.42
L	mm inch	341.5 13.45	375 14.76	425 16.69
N	mm inch	155.5 6.12	173.5 6.83	203.5 8.01
O	mm inch	100 3.94	118 4.65	140 5.51
P	mm inch	58 2.28	58 2.28	58 2.28
Q	mm inch	25 0.98	25 0.98	25 0.98
T	mm inch	186 7.32	201.5 7.93	221.5 8.72
U	mm inch	55 2.17	55 2.17	55 2.17
V	mm inch	56 2.2	56 2.2	56 2.2
W	mm inch	72 2.83	72 2.83	72 2.83
W1	mm inch	36.5 1.44	36.5 1.44	36.5 1.44

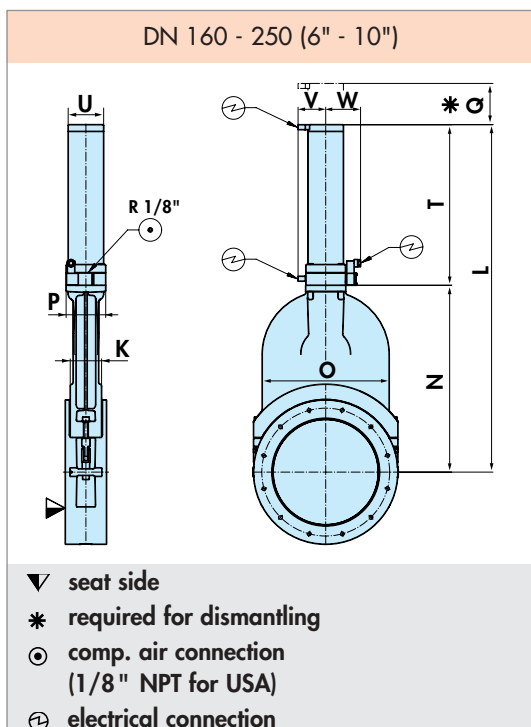

DN	mm inch	160 6	200 8	250 10
K	mm inch	58 2.28	66 2.6	76 2.99
L	mm inch	547 21.54	688 27.09	843 33.19
N	mm inch	280 11.02	363.5 14.31	453 17.83
O	mm inch	192 7.56	240 9.45	308 12.13
P	mm inch	70 2.76	80 3.15	96 3.78
Q	mm inch	60 2.36	80 3.15	100 3.94
T	mm inch	267 10.51	324.5 12.78	390 15.35
U	mm inch	65 2.56	75 2.95	86 3.39
W	mm inch	71.5 2.82	76.5 3.01	84.5 3.33
V	mm inch	57 2.24	62 2.44	67 2.64

HV Gate valves

Flange dimensions

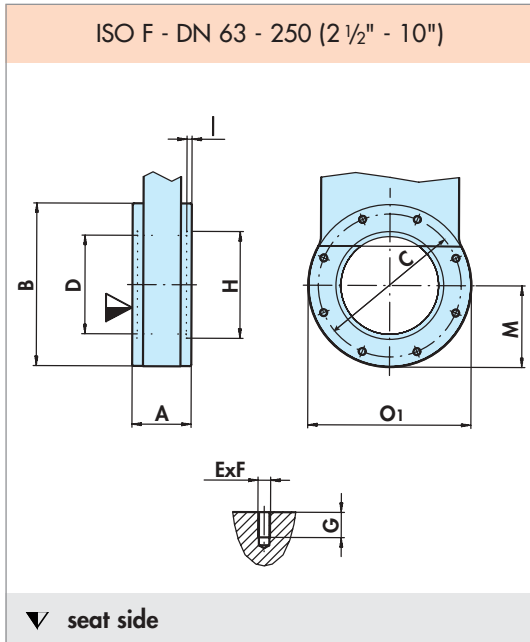

DN mm inch	63 2 1/2	80 3	100 4	160 6	200 8	250 10
A mm inch	60 2.36	60 2.36	60 2.36	70 2.76	80 3.15	100 3.94
B mm inch	130 5.12	145 5.71	165 6.5	235 9.25	288 11.34	350 13.78
C mm inch	110 4.33	125 4.92	145 5.71	200 7.87	260 10.24	310 12.2
D mm inch	65 2.56	80 3.15	100 3.94	150 5.91	200 7.87	261 10.27
E x F	4 x M8	8 x M8	8 x M8	8 x M10	12 x M10	12 x M10
G mm inch	12 0.47	12 0.47	12 0.47	16 0.63	16 0.63	16 0.63
H mm inch	70 2.76	83 3.27	102 4.02	153 6.02	213 8.39	- -
I mm inch	3 0.12	3 0.12	3 0.12	5 0.2	5 0.2	- -
M mm inch	65.5 2.58	73 2.87	83 3.27	117.5 4.63	144 5.67	175 6.89
O1 mm inch	131 5.16	146 5.75	166 6.54	237 9.33	290 11.42	352 13.86

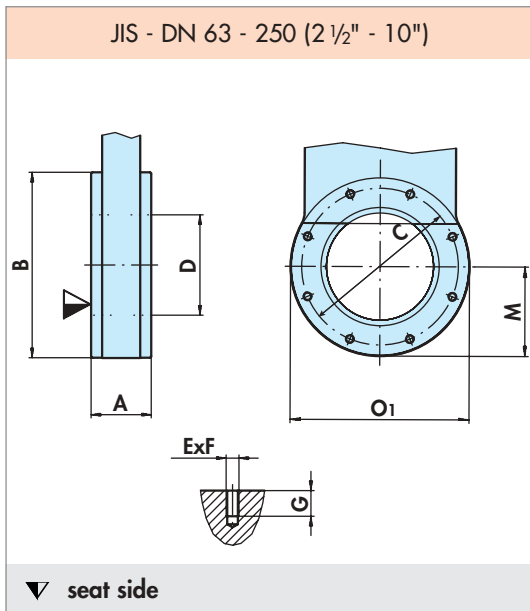

DN mm inch	63 2 1/2	80 3	100 4	150 6	200 8	250 10
A mm inch	60 2.36	60 2.36	60 2.36	70 2.76	80 3.15	100 3.94
B mm inch	145 5.71	160 6.3	185 7.28	235 9.25	288 11.34	350 13.78
C mm inch	120 4.72	135 5.31	160 6.3	210 8.27	270 10.63	320 12.6
D mm inch	65 2.56	80 3.15	100 3.94	150 5.91	200 7.87	261 10.27
E x F	4 x M10	4 x M10	8 x M10	8 x M10	8 x M12	12 x M12
G mm inch	12 0.47	12 0.47	12 0.47	16 0.63	16 0.63	16 0.63
M mm inch	73 2.87	81 3.19	93 3.66	117.5 4.63	144 5.67	175 6.89
O1 mm inch	146 5.75	161 6.34	186 7.32	237 9.33	290 11.42	352 13.86

UHV Gate valves

DN 63 - 250

Main Specifications	
Stainless steel body	
Cycles until first service:	50 000
Bake-out temperature:	
• Valve	≤ 250 °C (open) ≤ 200 °C (closed)
• Manual actuator	250 °C
• Pneumatic actuator	200 °C
• Position indicator	80 °C
• Solenoid	50 °C
Leak rate:	
• Body	< 5.10 ⁻¹⁰ mbar.l/s
• Seat	< 1.10 ⁻⁹ mbar.l/s
Pressure range:	
DN 63 - 200:	1.10 ⁻¹⁰ mbar to 1.6 bar (abs)
DN 250:	1.10 ⁻¹⁰ mbar to 1.2 bar (abs)
Differential pressure on the gate:	
DN 63 - 200:	≤ 1.6 bar in either direction
DN 250:	≤ 1.2 bar in either direction
Max differential pressure at opening: ≤ 30 mbar	
Seals:	
• Gate	FPM
• Bonnet	metal
Shaft feedthrough: non lubricated bellows	



UHV Gate valves DN 63 - 250

(stainless steel body, bellows sealed)

Manual and pneumatic actuators

(double acting cylinder, with position indicator and solenoid)

Flange DN		PART NUMBER			
mm	inch	CF-F metric threads	CF-F UNF threads	ISO-F	ASA-LP
63	2 1/2	30000 *	30005 *	30010 *	30015 *
80	3	30547 *	30548 *	30549 *	30550 ^{*(1)}
100	4	30001 *	30006 *	30011 *	30016 *
160	6	30002 *	30007 *	30012 *	30017 *
200	8	30003 *	30008 *	30013 *	30018 *
250	10	30004 *	30009 *	30014 *	30019 *

* please indicate the appropriate letter:

- M for manual actuators

- for pneumatic actuator, one of the options A, B, E, F, G, H, I, K, U from voltages table page C25.04.

- ⁽¹⁾ 30550 *: on request.

Seal kits (see page C25.04)

For UHV gate valves DN 63 - 250

Manual and pneumatic actuators

Flange DN		PART NUMBER
mm	inch	
63	2 1/2	30100K
80	3	30551K
100	4	30101K
160	6	30102K
200	8	30103K
250	10	30104K

UHV Gate valves DN 63 - 250

Technical data

DN (nom. I. D)		Standard flanges			Molecular flow conductance	Manual			Pneumatic						
		ISO-F	CF-F	ASA-LP ASA		Turns per stroke	Weight		Compressed air pressure min. - max. overpressure		Volume of air cylinder		Closing or opening time	Weight	
mm	inch		O.D		l/s	n	kg	lbs	bar	psig	l	Ft3	s	kg	lbs
63	2½	63	4½	2	600	10	9	20	4-7	55-100	0.08	.0028	1.0	9	20
80	3	80	4½	-	800	10	9	20	4-7	55-100	0.08	.0028	1.0	9	20
100	4	100	6	3	1700	13	12	26	4-7	55-100	0.11	.0038	1.2	12	26
160	6	160	8	4	6000	17	18	40	4-7	55-100	0.14	.0049	1.5	18	40
200	8	200	10	6	12000	17	29	62	4-7	55-100	0.25	.0087	2.0	28	62
250	3	250	12	8	26000	-	52	114	5-7	70-100	0.35	.0122	4.0	42	92

Dimensions manual actuator

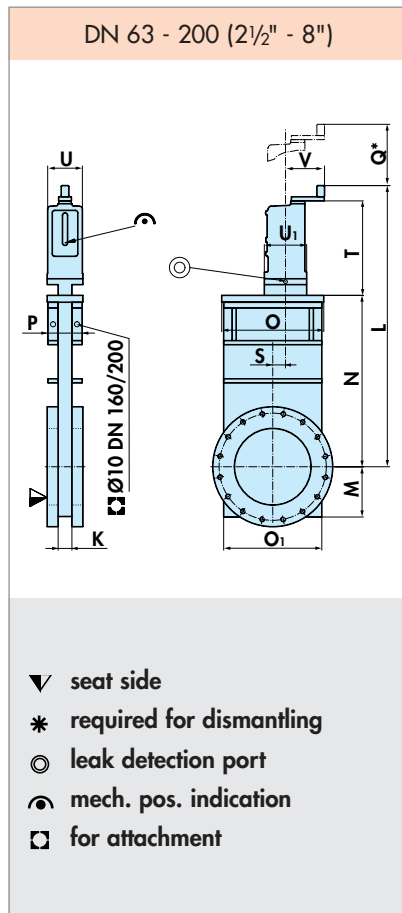

DN	mm inch	63 2½	80 3	100 4	160 6	200 8
K	mm	27	27	27	27	35
	inch	1.06	1.06	1.06	1.06	1.38
L	mm	408	421	462	552	660
	inch	16.06	16.57	18.19	21.73	25.98
M	mm	57	57	73	99	125
	inch	2.24	2.24	2.87	3.90	4.92
N	mm	192	205	247	336	430
	inch	7.56	8.07	9.72	13.23	16.93
O	mm	115	115	145	200	250
	inch	4.53	4.53	5.71	7.87	9.84
O1	mm	112	112	142	192	240
	inch	4.41	4.41	5.59	7.56	9.45
P	mm	70	70	70	70	80
	inch	2.76	2.76	2.76	2.76	3.15
Q	mm	180	180	220	290	350
	inch	7.09	7.09	8.66	11.42	13.78
S	mm	11	11	9	25	38.5
	inch	0.43	0.43	0.35	0.98	1.52
T	mm	184	184	184	184	200
	inch	7.24	7.24	7.24	7.24	7.87
U	mm	70	70	70	70	90
	inch	2.76	2.76	2.76	2.76	3.54
U1	mm	83	83	83	83	103
	inch	3.27	3.27	3.27	3.27	4.06
V	mm	77	77	77	77	94
	inch	3.03	3.03	3.03	3.03	3.70

UHV Gate valves

DN 63 - 200

Dimensions pneumatic actuator

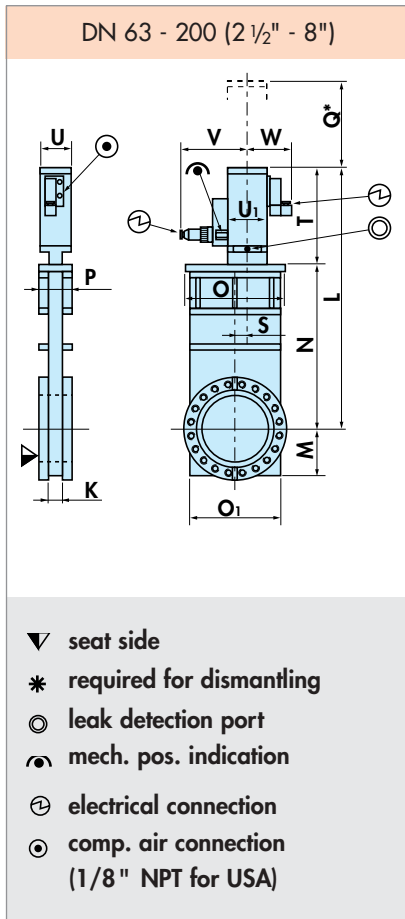

DN	mm	63	80	100	160	200	250
	inch	2 1/2	3	4	6	8	10
K	mm	27	27	27	27	35	41
	inch	1.06	1.06	1.06	1.06	1.38	1.61
L	mm	346	358	418	523	630	800
	inch	13.62	14.07	16.46	20.59	24.80	31.50
M	mm	57	57	73	99	125	161
	inch	2.24	2.24	2.87	3.90	4.92	6.34
N	mm	192	205	247	336	430	559
	inch	7.56	8.07	9.72	13.23	16.93	22
O	mm	115	115	145	200	250	345
	inch	4.53	4.53	5.71	7.87	9.84	13.50
O1	mm	112	112	142	192	240	322
	inch	4.41	4.41	5.59	7.56	9.45	12.6
P	mm	70	70	70	70	80	80
	inch	2.76	2.76	2.76	2.76	3.15	3.15
Q	mm	180	180	220	290	350	450
	inch	7.09	7.09	8.66	11.42	13.78	17.72
S	mm	11	11	9	25	38.5	65
	inch	0.43	0.43	0.35	0.98	1.52	2.56
T	mm	154	154	171	187	200	240
	inch	6.06	6.06	6.73	7.36	7.87	9.45
U	mm	70	70	70	70	90	90
	inch	2.76	2.76	2.76	2.76	3.54	3.54
U1	mm	83	83	83	83	103	103
	inch	3.27	3.27	3.27	3.27	4.06	4.06
V	mm	145	145	145	145	155	155
	inch	5.71	5.71	5.71	5.71	6.10	6.10
W	mm	77	77	77	77	87	87
	inch	3.03	3.03	3.03	3.03	3.42	3.42

UHV Gate valves

Flanges dimensions

ISO F - DN 63 - 250 (2 1/2" - 10")

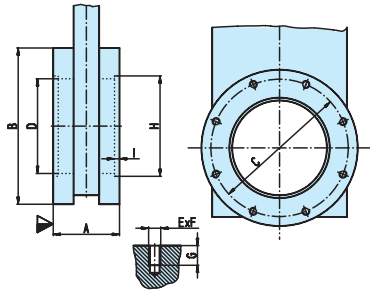

▼ seat side

DN mm	63	80	100	160	200	250
inch	2 1/2	3	4	6	8	10
A mm	70	70	70	70	80	100
inch	2.76	2.76	2.76	2.76	3.15	3.94
B mm	130	145	165	225	285	350
inch	5.12	5.71	6.5	8.86	11.22	13.78
C mm	110	125	145	200	260	310
inch	4.33	4.92	5.71	7.87	10.24	12.2
D mm	70	76	100	150	200	261
inch	2.76	3	3.94	5.91	7.87	10.27
E x F	4 x M8	8 x M8	8 x M8	8 x M10	8 x M10	12 x M10
G mm	13	13	13	15	15	15
inch	0.51	0.51	0.51	0.59	0.59	0.59
H mm	-	83	102	153	213	-
inch	-	3.27	4.02	6.02	8.39	-
I mm	-	4.5	3	5	5	-
inch	-	0.18	0.12	0.2	0.2	-

CF - F - DN 63 - 250 (2 1/2" - 10")
Metric threads

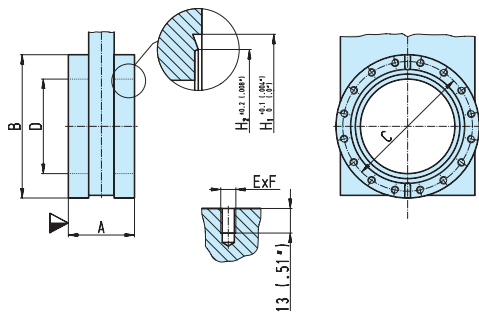

▼ seat side

DN mm	63	80	100	160	200	250
inch	2 1/2	3	4	6	8	10
O.D. inch	4 1/2	4 1/2	6	8	10	12
A mm	70	70	70	70	80	100
inch	2.76	2.76	2.76	2.76	3.15	3.94
B mm	113.5	117.5	151.6	202.4	253.2	350
inch	4.47	4.63	5.97	7.97	9.97	13.78
C mm	92.1	102.4	130.2	181	231.8	284
inch	3.63	4.08	5.13	7.13	9.13	11.18
D mm	70	76	100	150	200	254
inch	2.76	3	3.94	5.91	7.87	10
E x F	8 x M8	10 x M8	16 x M8	20 x M8	24 x M8	32 x M8
H1 mm	82.5	91.5	120.65	171.45	222.3	273.15
inch	3.25	3.6	4.75	6.75	8.75	10.75
H2 mm	77.4	86.3	115.5	166	217	267
inch	3.05	3.4	4.55	6.54	8.54	10.51

CF - F - DN 63 - 250 (2 1/2" - 10")
UNF threads

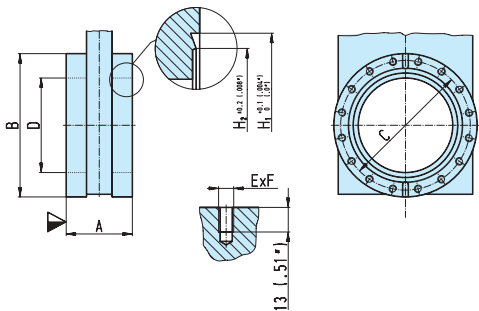

▼ seat side

DN mm	63	80	100	160	200	250
inch	2 1/2	3	4	6	8	10
O.D. inch	4 1/2	4 1/2	6	8	10	12
A mm	70	70	70	70	80	100
inch	2.76	2.76	2.76	2.76	3.15	3.94
B mm	113.5	117.5	151.6	202.4	253.2	350
inch	4.47	4.63	5.97	7.97	9.97	13.78
C mm	92.1	102.4	130.2	181	231.8	284
inch	3.63	4.08	5.13	7.13	9.13	11.18
D mm	70	76	100	150	200	254
inch	2.76	3	3.94	5.91	7.87	10
E x F	8 x 5/16"	10 x 5/16"	16 x 5/16"	20 x 5/16"	24 x 5/16"	32 x 5/16"
	24 UNF	24 UNF	24 UNF	24 UNF	24 UNF	24 UNF
H1 mm	82.5	91.5	120.65	171.45	222.3	273.15
inch	3.25	3.6	4.75	6.75	8.75	10.75
H2 mm	77.4	86.3	115.5	166	217	267
inch	3.05	3.4	4.55	6.54	8.54	10.51

UHV Gate valves

Flanges dimensions

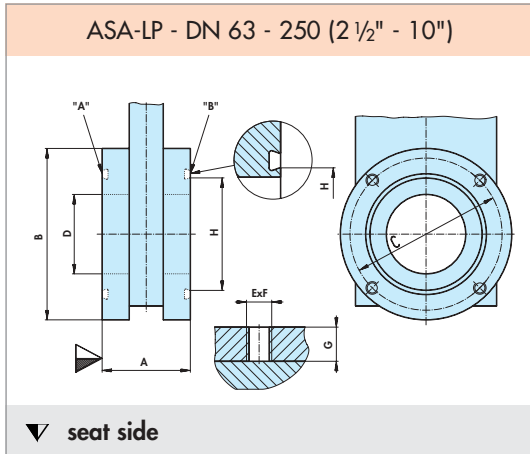

DN	mm	63	80	100	160	200	250
	inch	2 1/2	3	4	6	8	10
ASA - LP		2	-	3	4	6	8
A	mm	70	70	70	70	80	100
	inch	2.76	2.76	2.76	2.76	3.15	3.94
B	mm	152.4	177.8	190.5	225	279.4	350
	inch	6	7	7.5	8.86	11	13.78
C	mm	120.7	139.7	152.4	190.5	241.3	298.5
	inch	4.75	5.5	6	7.5	9.5	11.75
D	mm	70	76	100	150	200	254
	inch	2.76	3	3.94	5.91	7.87	10
E x F		4 x 3/8"	4 x 3/8"	4 x 3/8"	8 x 3/8"	8 x 3/4"	8 x 3/4"
		16 UNC	16 UNC	16 UNC	16 UNC	10 UNC	10 UNC
G	mm	15	15	15	15	19	19
	inch	0.59	0.59	0.59	0.59	0.75	0.75
H	mm	88.9	88.9	120.65	158.75	206.4	266.7
	inch	3.5	3.5	4.75	6.25	8.13	10.5
O'ring		88.49 x 3.53	88.49 x 3.53	120.24 x 3.53	158.34 x 3.53	202.79 x 3.53	266.29 x 3.53
I.D. X d		3.48 x 0.139	3.48 x 0.139	4.73 x 0.139	6.23 x 0.139	7.98 x 0.139	10.48 x 0.139

Butterfly valves

DN 63 - 200

Main Specifications

Stainless steel and aluminium body

Bellow sealed from atmosphere to UHV

Linear movement with patented spiral mechanism, first swing, then pivot, no friction from the plate seal.

Leak rate

• Body <math> < 1 \cdot 10^{-9}</math> mbar.l/s

• Seat <math> < 1 \cdot 10^{-9}</math> mbar.l/s

Pressure range $1 \cdot 10^{-8}$ mbar to 2 bar (abs)

Differential pressure on the plate
 ≤ 1.2 bar in opening direction
 ≤ 1.6 bar in closing direction

Max differential pressure at opening: ≤ 500 mbar

Cycles until first service 100 000

Bake-out temperature

• Valve ≤ 120 °C

• Position indicator ≤ 80 °C

• Solenoid ≤ 50 °C

Seals

• Plate FPM

• Bonnet FPM

Feedthrough bellow



Butterfly valves

(Aluminium or stainless steel body, bellows sealed)

Pneumatic actuators

(double acting cylinder with position indicator and solenoid)

Seal kits (See p. C25.04)

DN 63 - 200

Pneumatic actuators

Flange DN		PART NUMBER	PART NUMBER
mm	inch	Aluminium ISO-F	Stainless steel ISO-F
63	2 1/2	31037 *	31041 *
80	3	31553 *	31554 *
100	4	31038 *	31042 *
160	6	31039 *	31043 *
200	8	31040 *	31044 *

Flange DN		PART NUMBER
mm	inch	
63	2 1/2	31114K
80	3	31555K
100	4	31115K
160	6	31116K
200	8	31117K

* Please indicate the appropriate letter:

- for pneumatic actuator, one of the options A, B, E, G, H, U
 from voltages table page C25.04.

Butterfly valves

DN 63 - 200

Technical data

DN (nom. I. D)		Standard flanges		Molecular flow conductance	Pneumatic								
		ISO-F	CF-F		Compressed air pressure min. - max. overpressure		Volume of air cylinder		Closing or opening time	Weight			
										Stainless steel body		Aluminium	
mm	inch		O.D	l/s	bar	psig	l	ft ³	s	kg	lbs	kg	lbs
63	2½	63	4½	550	4 - 7	60-100	0.04	.0014	0.4	4.6	10.1	2.3	5.1
80	3	80	-	700	4 - 7	60-100	0.08	.0003	0.8	7.5	16.5	3.8	8.4
100	4	100	6	1400	4 - 7	60-100	0.08	.0003	0.8	8	17.6	4	8.8
160	6	160	8	3500	4 - 7	60-100	0.13	.0045	1.4	15.6	34.4	7.4	16.3
200	8	200	10	7500	4 - 7	60-100	0.30	.001	1.8	34.2	75.4	16.1	35.5

Butterfly valves DN 63 - 200

Dimensions pneumatic actuator

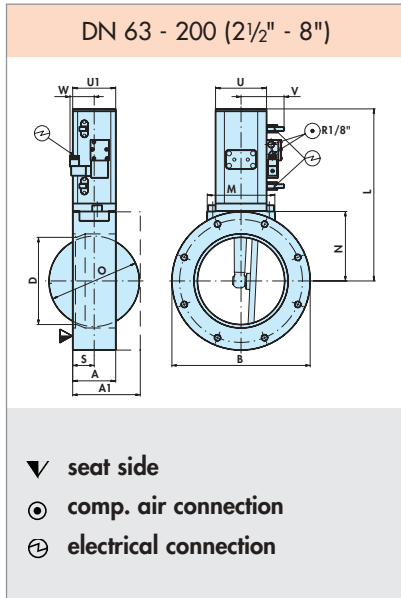

DN	mm inch	63 2½	80 3	100 4	160 6	200 8
A	mm inch	50 1.97	60 2.36	60 2.36	70 2.76	90 3.54
B	mm inch	130 5.12	145 5.71	165 6.5	225 8.86	300 11.81
D	mm inch	63 2.48	76 2.99	95 3.74	142 5.59	192 7.56
L	mm inch	181 7.13	228 8.98	228 8.98	285 11.22	371 14.61
M	mm inch	76 2.99	86 3.39	86 3.39	110 4.33	140 5.51
N	mm inch	65 2.56	82.5 3.25	82.5 3.25	113 4.45	147.5 5.81
O	mm inch	67 2.64	80 3.15	100 3.94	147 5.79	200 7.87
S	mm inch	25 0.98	30 1.18	30 1.18	35 1.38	45 1.77
U	mm inch	60 2.36	70 2.76	70 2.76	83 3.27	103 4.06
U1	mm inch	50 1.97	60 2.36	60 2.36	70 2.76	90 3.54
V	mm inch	60 2.36	65 2.56	65 2.56	70 2.76	80 3.15
W	mm inch	44 1.73	40 1.57	40 1.57	40 1.57	30 1.18

Flange dimensions

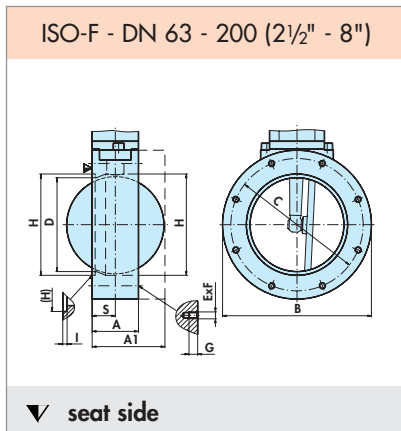

DN	mm inch	63 2½	80 3	100 4	160 6	200 8
A	mm inch	50 1.97	60 2.36	60 2.36	70 2.76	90 3.54
B	mm inch	130 5.12	145 5.71	165 6.5	225 8.86	300 11.81
C	mm inch	110 4.33	125 4.92	145 5.71	200 7.87	260 10.24
D	mm inch	63 2.48	76 2.99	95 3.74	142 5.59	192 7.56
E x F		4 x M8	8 x M8	8 x M8	8 x M10	12 x M10
G	mm inch	12 0.47	12 0.47	12 0.47	15 0.59	15 0.59
H	mm inch	70 2.76	83 3.27	102 4.02	153 6.02	213 8.39
I	mm inch	2.5 0.1	2.5 0.1	2.5 0.1	4.5 0.18	4.5 0.18
S	mm inch	25 0.98	30 1.18	30 1.18	35 1.38	46 1.77

Butterfly valves

DN 40 - DN 50

Main Specifications

Stainless steel body

Bronze shaft

Quarter turn for opening and closing

Visual indication of valve position

Closes and opens against atmospheric pressure

Leak rate:

- External 10^{-8} mbar.l/s
- Plate 10^{-8} mbar.l/s

Conductance: DN 40: 135 l/s at 1 mbar

DN 50: 385 l/s at 1 mbar

Seal: Perbunan



Ordering information

Manual actuator

Flange DN		PART NUMBER ISO-KF	PART NUMBER Seal kits
mm	inch		
40	1 1/2	786557	033591
50	2	786365	033592

Dimensions in mm

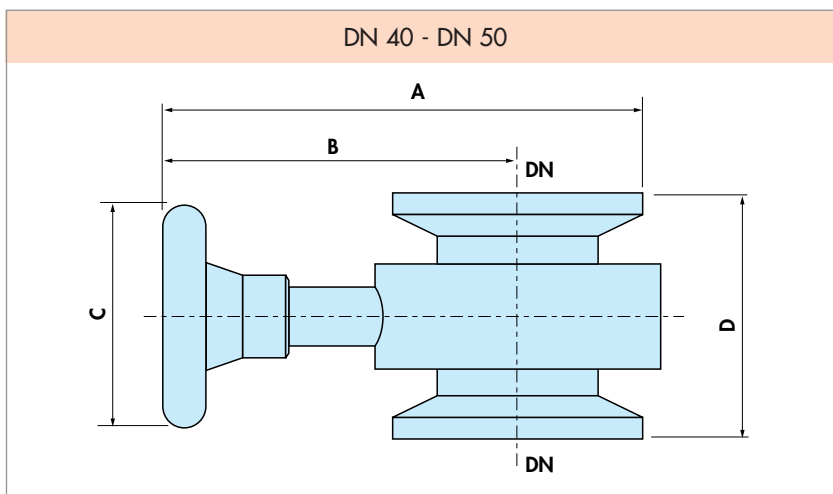

DN mm	40	50
A	97.5	152.5
B	68	111
C	40	70
D	44	60
Weight (g)	550	1350

Butterfly valves

Double butterfly valve DN 40

Main Specifications

Stainless steel body

Two butterfly plates in the same body

In-line main way, angle by-pass port with smooth tube 27.5 mm O.D.

Quarter turn for opening and closing

Visual indication of valve position

Leak rate:

- External 10^{-8} mbar.l/s
- Plate 10^{-8} mbar.l/s

Seals: Perbunan

Weight: 1600 g



Ordering information

Manual actuator

Flange DN		PART NUMBER ISO-KF	PART NUMBER Seal kits
mm	inch		
40	1 1/2	786558	033590

Dimensions in mm

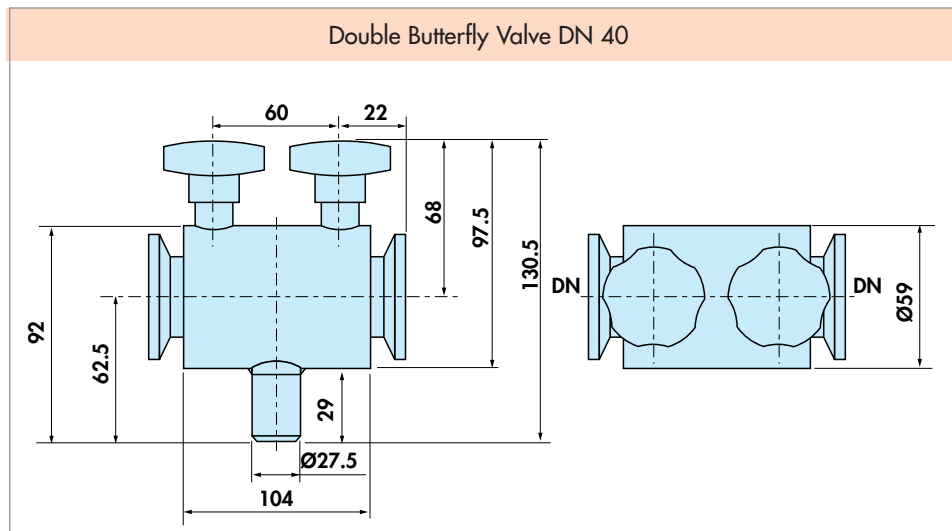

Butterfly valves

Three port butterfly valves DN 25 - DN 40

Main Specifications

Stainless steel body

Bronze shaft

Quarter turn for opening and closing

Visual indication of valve position

Closes and opens against atmospheric pressure

Leak rate:

- External 10⁻⁸ mbar.l/s
- Plate 10⁻⁸ mbar.l/s

Conductance:
DN 25: 65 l/s at 1 mbar
DN 40: 135 l/s at 1 mbar

Seal: Perbunan



Ordering information

Manual actuator

Flange DN		PART NUMBER ISO-KF	PART NUMBER seal kits
mm	inch		
25	1	786967	033588
40	1 1/2	785121	033589

Dimensions in mm

DN mm	25	40
A	50	70
B	109	114
C	24.5	34.5
D	65	65
E	54.5	62
Weight (g)	550	3300

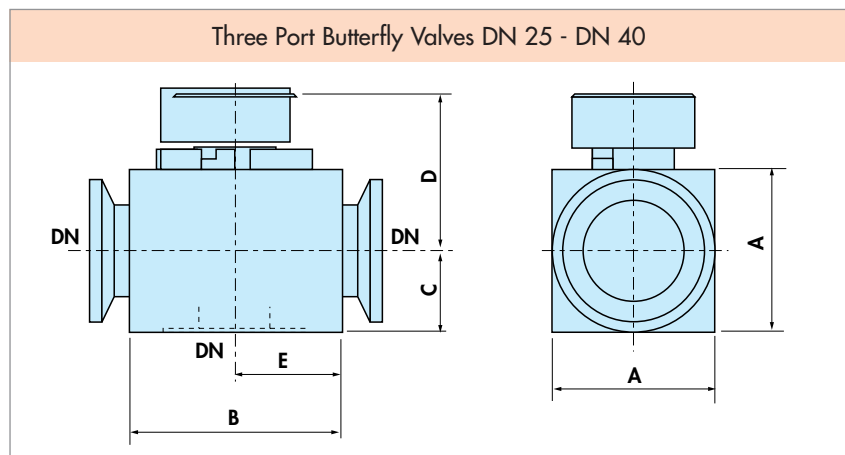

Angle valves

HV Angle valves DN 16 - 160

Main Specifications	
Stainless steel and aluminium body	
Bellows feedthrough	
Cycles until first service	DN 16 - 80: 3 millions DN 100 - 160: 1 million
Leak rate: Body, Seat	<1.10 ⁹ mbar.l/s
Pressure range (open and closed in closing direction) :	DN 16 - 50: 1.10 ⁸ mbar to 4 bar (abs) DN 63 - 160: 1.10 ⁸ mbar to 5 bar (abs)
Max. differential pressure at opening:	≤ 1 bar in either direction
Differential pressure on the plate	
Manual actuator:	DN 16 - 25: 4 bar DN 40 - 50: 3 bar DN 63: 2 bar
Pneumatic actuator:	DN 16 - 63: 2 bar DN 100 - 160: 1.2 bar
Bake-out temperature:	
• Valve body	≤ 150 °C
• Manual and pneumatic actuator	≤ 150 °C
• Position indicator	≤ 80 °C
• Solenoid	≤ 80 °C
Seals:	
• Plate, Bonnet	FPM



HV Angle valves DN 16 - 160

(aluminium or stainless steel body, bellows sealed)

Manual and pneumatic actuators

(single acting cylinders, with position indicator and solenoid)

Seal kits (see page C25.04)

HV DN 16 - 160

Manual and pneumatic actuators

Flange DN		PART NUMBER - Aluminium		PART NUMBER - Stainless steel	
mm	inch	ISO-KF	ISO-K	ISO-KF	ISO-K
16	5/8	31062 *		31069 *	
25	1	31063 *		31070 *	
40	1 1/2	31064 *		31071 *	
50	2	31065 *		31072 *	
63	2 1/2		31066 *		31073 *
80	3		31542 *		
100	4		31067 *		
160	6		31068 *		

Flange DN		PART NUMBER
mm	inch	
16	5/8	31132K
25	1	31133K
40	1 1/2	31134K
50	2	31135K
63	2 1/2	31136K
80	3	31543K
100	4	31530K
160	6	31531K

* Please indicate the appropriate letter: - M for manual actuator

- for pneumatic actuator, one of the options DN 16 - 50: A, B, F, H / DN 63 - 160: A, B, F, H, J, S, L, P, V, Q, R from the voltages table page C25.04.

- DN 100 - DN 160 not available with manual actuator

Angle valves

HV Angle valves DN 16 - 160

Technical data

DN (nom. I. D)		Standard flanges		Manual						Pneumatic									
				Molecular flow conductance	Turns per stroke	Weight				Compressed air pressure min. - max. overpressure		Volume of air cylinder		Closing time	Weight				
		ISO-KF	ISO-K			Aluminium body		Stainless steel body							Aluminium body	Stainless steel body			
mm	inch			l/s	n	kg	lbs	kg	lbs	bar	psig	l	ft³	s	kg	lbs	kg	lbs	
16	5/8	16	-	5	3.6	0.20	0.441	0.26	0.573	4 - 8	60-115	0.004	0.0001	0.1	0.37	0.815	0.43	0.948	
25	1	25	-	14	3.8	0.27	0.595	0.34	0.750	4 - 8	60-115	0.011	0.0004	0.2	0.5	1.102	0.6	1.322	
40	1 1/2	40	-	45	4.5	0.6	1.323	0.75	1.653	4 - 8	60-115	0.035	0.0012	0.55	1.06	2.336	1.22	2.689	
50	2	50	-	80	4.8	0.94	2.072	1.1	2.425	4 - 8	60-115	0.047	0.0017	0.65	1.54	3.395	1.7	3.747	
63	2 1/2	-	63	160	6.6	2.9	6.393	1.7	3.748	4 - 8	60-115	0.112	0.0040	0.7	2.99	6.591	1.79	3.946	
80	3	-	80	200	6.6	3.1	6.834	-	-	4 - 8	60-115	0.112	0.0040	0.7	3.19	7.032	-	-	
100	4	-	100	440	-	-	-	-	-	4 - 8	60-115	0.330	0.0117	1.0	8.09	17.835	-	-	
160	6	-	160	1000	-	-	-	-	-	4 - 8	60-115	1.050	0.0371	2.00	14.79	30.622	-	-	

Dimensions Manual actuator

DN 16 - 50 (5/8" - 2") ISO-KF

▼ seat side
 * required for dismantling
 ○ leak detection port
 ◐ mech. pos. indication

DN	mm	16	25	40	50
	inch	5/8	1	1 1/2	2
A	mm	40	50	65	70
	inch	1.57	1.97	2.56	2.76
B	mm	40	48	65	77
	inch	1.57	1.89	2.56	3.03
D	mm	16	25	40	50
	inch	0.63	0.98	1.57	1.97
L	mm	64.9	60.9	94.3	101.1
	inch	2.56	2.4	3.71	3.98
L1	mm	67.4	64.3	97.3	104.1
	inch	2.65	2.53	3.83	4.1
Q	mm	46	44	73.5	85.5
	inch	1.81	1.73	2.89	3.35
V	mm	40	40	60	60
	inch	1.57	1.57	2.36	2.36
Z	mm	3.6	4.7	7.9	9.3
	inch	0.14	0.19	0.31	0.37

L: aluminium
 L1: stainless steel

Angle Valves

HV Angle Valves DN 16 - 160

Dimensions Manual actuator

DN 63 - 80 (2 1/2" - 3) ISO-K

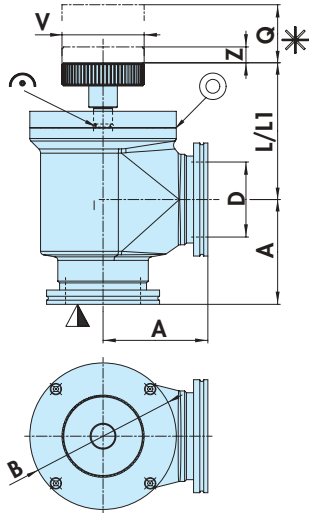

- ▼ seat side
- * required for dismantling
- ⊙ leak detection port
- ◌ mech. pos. indication

DN	mm inch	63 2 1/2	80 3
A	mm inch	68 3.46	88 3.46
B	mm inch	123 4.84	123 4.84
D	mm inch	63 2.5	80 3
L	mm inch	114.8 4.52	114.8 4.52
L1	mm inch	114.8 4.52	114.8 4.52
Q	mm inch	105 4.13	105 4.13
V	mm inch	69 2.72	69 2.72
Z ¹⁾	mm inch	13.3 0.55	13.3 0.55

L: aluminium
L1: stainless steel

Angle valves

HV Angle valves DN 16 - 160

Dimensions Pneumatic Actuator

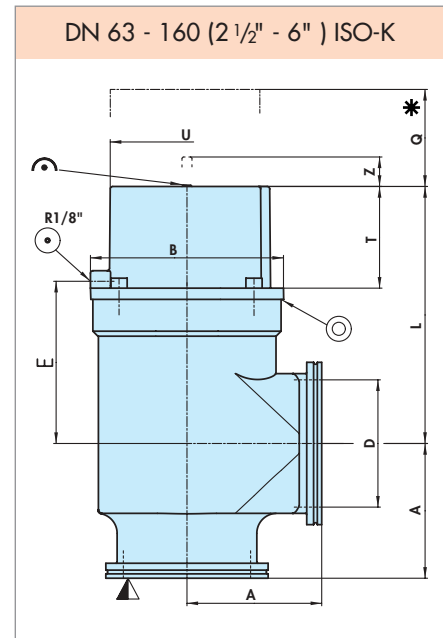
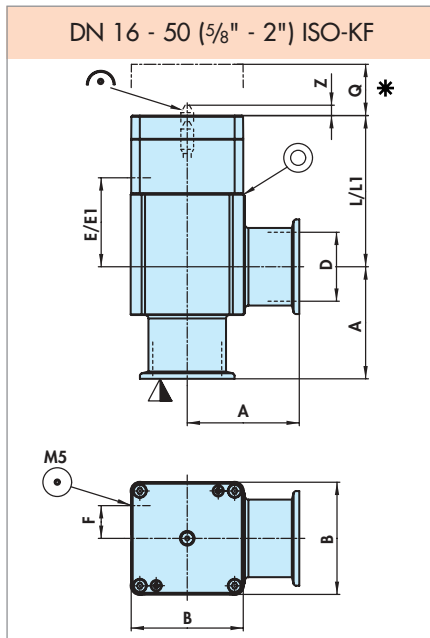

- ▼ seat side
- * required for dismantling
- mech. pos. indication
- ⊖ leak detection port
- ⊕ comp. air connection (1/8" NPT for USA)

DN	mm	16	25	40	50	DN	mm	63	80	100	160
	inch	5/8	1	1 1/2	2		inch	2 1/2	3	4	6
A	mm	40	50	65	70	A	mm	88	90	108	138
	inch	1.57	1.97	2.56	2.76		inch	3.46	3.54	4.25	5.43
B	mm	40	48	65	77	B	mm	123	123	155	216
	inch	1.57	1.89	2.56	3.03		inch	4.84	4.84	6.1	8.5
D	mm	16	25	40	50	D	mm	63	80	102	153
	inch	0.63	0.98	1.57	1.97		inch	2.48	3.15	4.02	6.02
E	mm	35.6	30.6	51.6	58.4	E	mm	71.4	71.4	131	117
	inch	1.4	1.2	2.03	2.3		inch	2.81	2.81	5.16	4.61
E1	mm	38.1	34	54.6	61.4	L	mm	123	123	206.5	202
	inch	1.5	1.34	2.15	2.42		inch	4.84	4.84	8.13	7.95
F	mm	9	13	18.9	20	Q	mm	105	105	170	195
	inch	0.35	0.51	0.74	0.79		inch	4.13	4.13	6.69	7.68
L	mm	65.2	60.6	87.7	96	T	mm	45.1	45.1	81	86.5
	inch	2.57	2.38	3.45	3.78		inch	1.78	1.78	3.19	3.41
L1	mm	67.7	64	90.7	99	U	mm	94	94	123	180
	inch	2.67	2.52	3.57	3.9		inch	3.7	3.7	4.84	7.09
Q	mm	46	44	73.5	85.5	Z	mm	21.6	21.6	6	6
	inch	1.81	1.73	2.89	3.35		inch	0.85	0.85	0.24	0.24
Z	mm	2	4	9.5	10.5						
	inch	0.08	0.16	0.37	0.41						

E: aluminium
 E1: stainless steel
 L: aluminium
 L1: stainless steel

Angle valves

UHV Angle valves DN 16 - 40 - 63

Main Specifications

Formed stainless steel body without corners

Extremely low outgassing rate

Suited for most corrosive gases

Bellow sealed

Cycles until first service: DN 16 - 40: 3 millions
DN 63: 1 million

Leak rate:

- Body < 5.10⁻¹⁰ mbar.l/s

- Seat < 1.10⁻⁹ mbar.l/s

Pressure range:

Open and closed in closing direction 1.10⁻¹⁰ mbar to 5 bar (abs)

Differential pressure on the plate in opening direction

Manual actuator: DN 16: ≤ 5 bar
DN 40: ≤ 3 bar
DN 63: ≤ 2 bar

Pneumatic actuator: DN 16 - 63: ≤ 2 bar

Max. differential pressure at opening: ≤ 1 bar in either direction

Bake-out temperature:

- Valve ≤ 200° C open, 150° C closed
- Manual and pneumatic actuator ≤ 150° C
- Position indicator ≤ 80° C
- Solenoid ≤ 80° C

Seals:

- Plate FPM
- Bonnet metal

Feedthrough: bellow



Manual and pneumatic actuator

(simple acting cylinder, with position indicator and solenoid)

Flange DN		PART NUMBER	
mm	inch	CF-R	SEAL KITS <i>(see page C25.04)</i>
16	5/8	30076 *	30139K
40	1 1/2	30077 *	30140K
63	2 1/2	30078 *	30141K

* Please indicate the appropriate letter: M for manual actuator, for pneumatic actuator, one of the options A, B, F, H, J, L, P, Q, R, S, V from the voltages table page C25.04.

Technical Data

				Manual			Pneumatic						
DN		CF-F flange	Molecular flow conductance	Turns per stroke	Weight		Compressed air pressure min. - Max. overpressure		Volume of air cylinder		Closing time	Weight	
mm	inch		l/s	n	kg	lbs	bar	psig	l	ft ³	s	kg	lbs
16	5/8	1 1/3	5	3	0.55	1.2	4 - 8	60 - 115	0.005	0.0002	0.05	0.7	1.54
40	1 1/2	2 3/4	45	6	1.8	4.0	4 - 8	60 - 115	0.032	0.0011	0.3	2.0	4.4
63	2 1/2	4 1/2	160	8.5	6.3	13.9	4 - 8	60 - 115	0.100	0.0035	0.7	6.3	13.9

Angle valves

UHV Angle Valves DN 16 - 40 - 63

Dimensions actuator

Manual actuator
DN 16 - 63 (5/8" - 2 1/2") CF-R

- ▼ seat side
- * required for dismantling
- ⊙ comp. air connection (1/8" NPT for USA)
- ⦿ mech. pos. indication

DN	mm inch	16 5/8	40 1 1/2	63 2 1/2
O.D	inch	1 1/3	2 3/4	4 1/2
A	mm	38	63	105
	inch	1.50	2.48	4.13
D	mm	16	40	64
	inch	0.63	1.57	2.52
E x F	mm	6 x 4.3	6 x 6.6	8 x 8.4
	inch	6 x .17	6 x .26	8 x .33
L	mm	93	118	154
	inch	3.66	4.65	6.06
P	mm	35	68	100
	inch	1.38	2.68	3.94
Q	mm	55	95	140
	inch	2.17	3.74	5.51
U	mm	47	82	109
	inch	1.85	3.23	4.29
V	mm	50	63	82
	inch	1.97	2.48	3.29
Z	mm	6	13	19
	inch	.24	.51	.75

Pneumatic actuator
DN 16 - 63 (5/8" - 2 1/2") CF-R

- ▼ seat side
- * required for dismantling
- ⊙ comp. air connection (1/8" NPT for USA)
- ⦿ mech. pos. indication

DN	mm inch	16 5/8	40 1 1/2	63 2 1/2
O.D	inch	1 1/3	2 3/4	4 1/2
A	mm	38	63	105
	inch	1.50	2.48	4.13
D	mm	16	40	64
	inch	.63	1.57	2.52
E X F	mm	6 x 4.3	6 x 6.6	8 x 8.4
	inch	6 x .17	6 x .26	8 x .33
L	mm	68	97	130
	inch	2.68	3.81	5.12
P	mm	35	68	100
	inch	1.38	2.68	3.94
Q	mm	55	95	140
	inch	2.17	3.74	5.51
U	mm	54	85	109
	inch	2.13	3.35	4.29
V	mm	20.5	34.5	46.5
	inch	0.81	1.36	1.83
Z	mm	6	13	18
	inch	.24	.51	.71

See page C25.28 for position indicator and solenoid dimensions

Angle valves

Flanges dimensions

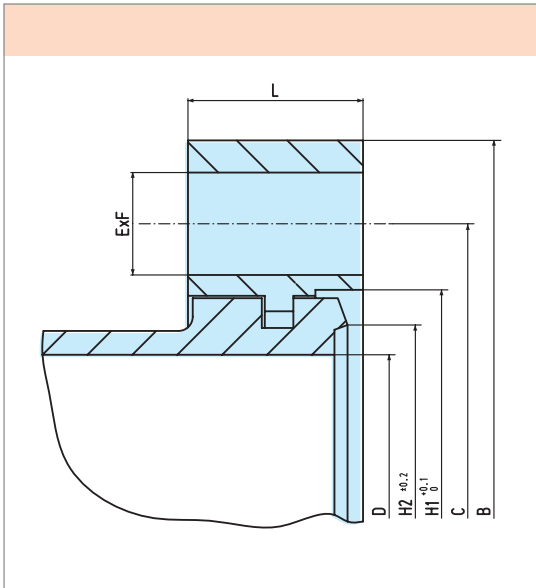

DN	mm inch	16 5/8	40 1 1/2	63 2 1/2
A	mm inch	38 1.50	63 2.48	105 4.13
B	mm inch	34 1.34	69.5 2.74	113.5 4.47
C	mm inch	27 1.06	58.7 2.31	92.1 3.63
D	mm inch	16 0.63	40 1.57	64 2.52
E x F	mm inch	6 x 4.3	6 x 6.6	8 x 8.4
H1	mm inch	21.4 0.84	48.3 1.9	82.5 3.25
H2	mm inch	18.5 0.73	42 1.65	77.4 3.05
K	mm inch	66 2.6	70 2.76	141.5 5.57
L	mm inch	7.3 0.29	13 0.51	19 0.75
M	mm inch	25.6 1	33.6 1.32	56.6 2.23
N	mm inch	27.5 1.08	51.7 2.04	74 2.91
O	mm inch	34 1.34	71 2.8	94 3.7
SW	mm inch	10 0.39	10 0.39	22 0.87
T	mm inch	30.5 1.2	-	51.5 2.03
U	mm inch	19 0.75	-	54 2.13
Z	mm inch	8.5 0.33	2.5 0.1	20 0.79

Position indicator and solenoid for pneumatic angle valve DN 16 to DN 43

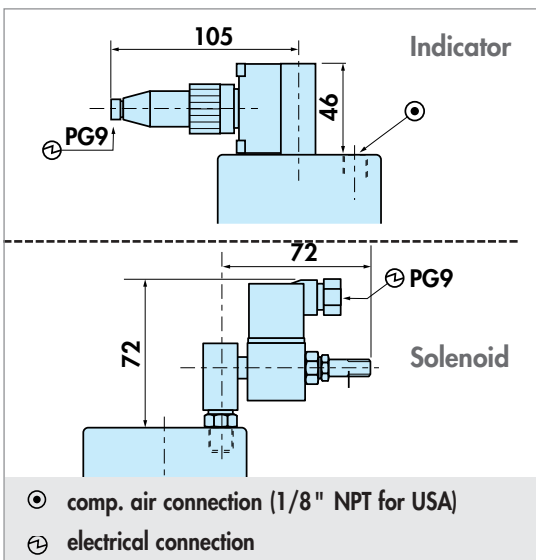

Vacuum valves

Electromagnetic Angle Valves DN 25 - 40

Main Specifications

Aluminium body

Electromagnetic actuator with solenoid and electronic booster (delivered with the valve)

Pressure range: <math> < 1.10^{-8}</math> mbar to 2 bar

Leak rate:

- Body <math> < 1.10^{-9}</math> mbar.l/s

- Seat <math> < 1.10^{-9}</math> mbar.l/s

Max. differential pressure at plate: 2 bar in either direction

Cycles until first service: 200 000

Max. strokes nb: 15 / mn at 20 °C

Working temperature: 0 °C to 40 °C

Seals:

- Body, Plate FPM

Ordering information

Normally closed (power off)

Flange DN		PART NUMBER	
mm	inch	ISO-KF	SEAL KITS <small>(see page C25.04)</small>
25	1	30082 *	30144K
40	1 1/2	30083 *	30145K

Delivered with electronic booster and coil. Normally closed (power off).

* Please indicate the appropriate letter: option D or C from the voltages table page C25.04.

Electronic booster and coil

(identical for both valve sizes)

Voltage - frequency	PART NUMBER
100/115 V - 50/60 Hz	30146Z
200/230 V - 50/60 Hz	30147Z

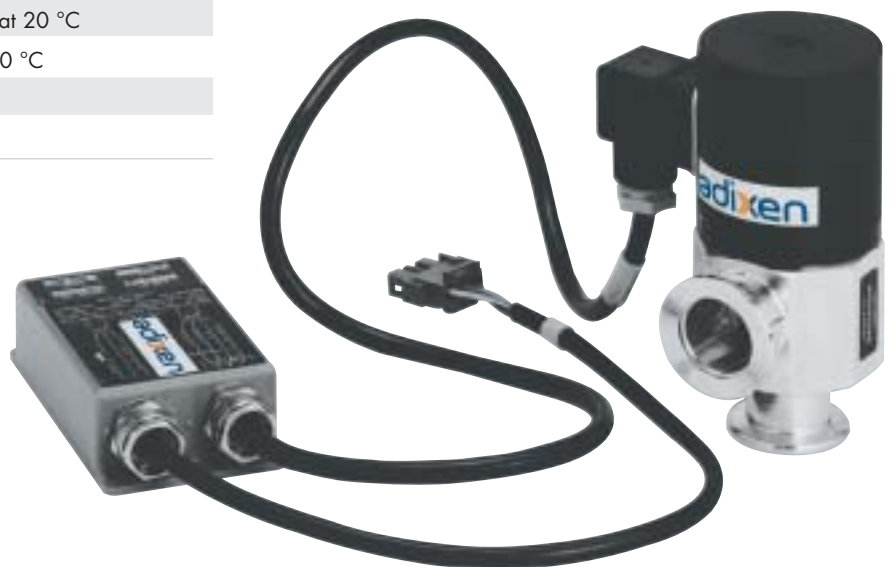

Technical data

	DN	25	40
Starting power	W	700	700
Holding power	W	8	8
Closing time	s	0.1	0.1
Opening time	s	0.1	0.1
Conductance molecular flow	l/s	14	45
Weight valve	kg	1.4	1.8
	lbs	3	4
Electronic booster	kg	1.8	0.4
	lbs	4	0.9

Vacuum valves

Electromagnetic angle valves DN 25 - 40

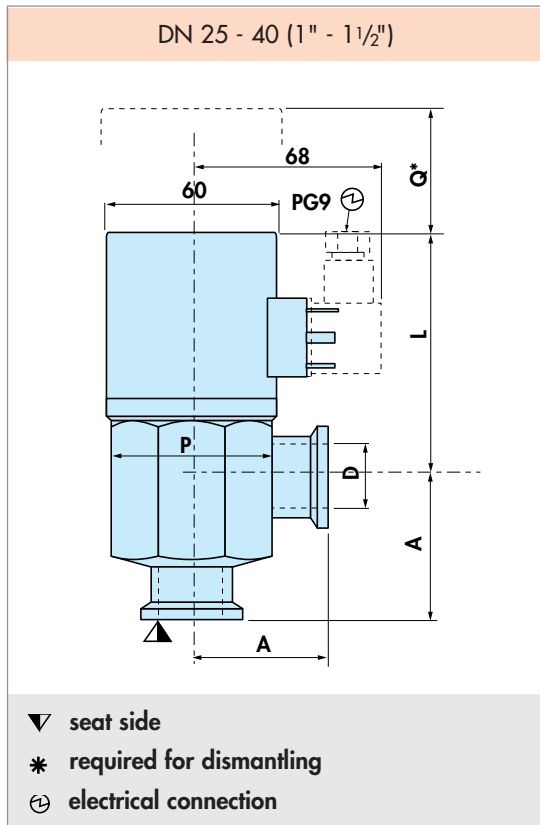

DN	mm inch	25 1	40 1½
A	mm inch	50 1.97	65 2.56
D	mm inch	25 0.98	40 1.57
L	mm inch	83 3.27	93 3.66
P	mm inch	57 2.24	78 3.07
Q	mm inch	60 2.37	60 2.36

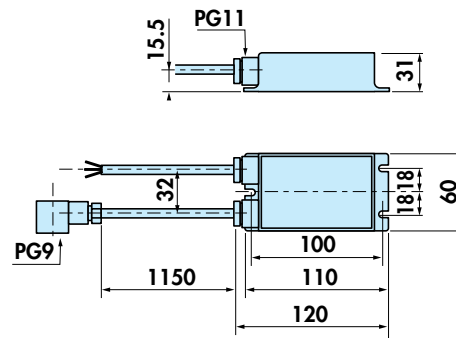

Special valves

Diaphragm valves DN 16 - 25 - 40

Main Specifications

Aluminium body

Suitable for isolation venting and rough flow regulation

For gas and liquid

Pressure range: $1 \cdot 10^{-7}$ mbar to 5 bar (abs)

Leak rate: Body, Seat $< 1 \cdot 10^{-9}$ mbar.l/s

Cycles until first service: 100 000

Bake-out temperature:

- Valve ≤ 150 °C

- Hand wheel ≤ 50 °C

Seal: FPM diaphragm

Weight DN 16 - 25 - 40: 0.16 - 0.50 - 1.2 kg

0.35 - 1.1 - 2.60 lbs



Ordering information

Manual Actuator

Flange DN		PART NUMBER	
mm	inch	ISO-KF	DIAPHRAGM
16	5/8	30052M	30122K
25	1	30053M	30123K
40	1 1/2	30054M	30124K

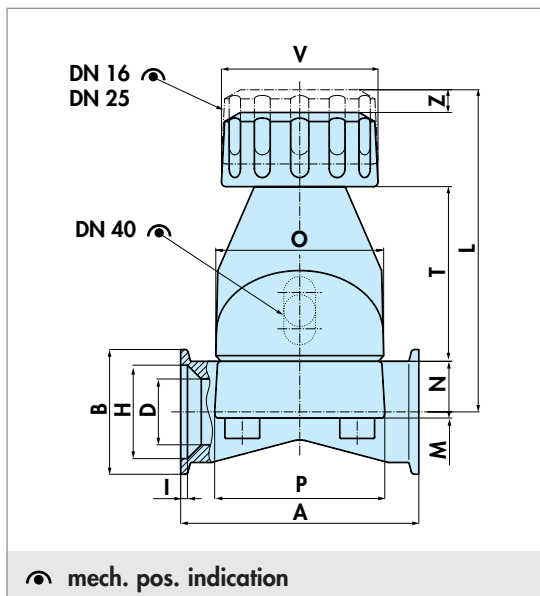

DN	mm inch	16 5/8	25 1	40 1 1/2
A	mm inch	52 2.05	80 3.15	105 4.13
B	mm inch	30 1.18	40 1.57	55 2.17
D	mm inch	15 .59	19 .75	29 1.14
H	mm inch	17.2 .68	26.2 1.03	41.2 1.62
I	mm inch	3 .12	3 .12	3 .12
L	mm inch	66.5 2.62	111 4.37	132 5.2
M	mm inch	10 .39	2 .08	2.7 .11
N	mm inch	10 .39	14 .55	22.3 .88
O	mm inch	32.5/32.5 1.28/1.28	54/54 2.13/2.13	74/79 2.91/3.11
P	mm inch	32/32 1.26/1.26	54/54 2.13/2.13	75/80 2.95/3.15
T	mm inch	30 1.18	56 2.2	77 3.03
V	mm inch	30 1.18	47.5 1.87	69 2.72
Z	mm inch	5.5 .22	10 .39	- -

Special valves

Three Way Ball Valves DN 16 - 25 - 40

Main Specifications

Nickel-plated brass body

Pressure range: 10^{-6} mbar to 20 bar

Leak rate:

- External 10^{-3} mbar.l/s
- Seat 10^{-3} mbar.l/s

Seals: Teflon and Perbunan

Ordering information

Manual Actuator

Flange DN		PART NUMBER ISO-KF
mm	inch	
16	5/8	785048
25	1	785049
40	1 1/2	785050



Dimensions in mm

DN	mm	16	25	40
A		70	108	260
B		46	60	95
C		75	100	194
D		40	50	65
Weight	(g)	450	1000	1500

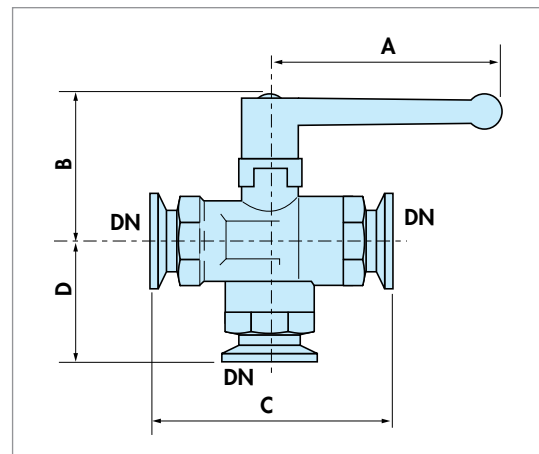

Special valves

Ball Valves DN 16 - DN 25

Main Specifications

Nickel-plated brass body	
Pressure range:	10 ⁻⁵ mbar to 20 bar
Leak rate:	
• External	10 ⁻³ mbar.l/s
• Seat	10 ⁻³ mbar.l/s
Conductance at 1 mbar:	DN 16: 24 l/s DN 25: 150.l/s
Seals:	Teflon and Perbunan

Ordering information Manual Actuator

Flange DN		PART NUMBER ISO-KF
mm	inch	
16	5/8	786367
25	1	786368



Dimensions in mm

DN	mm	16	25
A		70	108
B		46	60
C		75	100
D		107.5	158
Weight	(g)	360	800

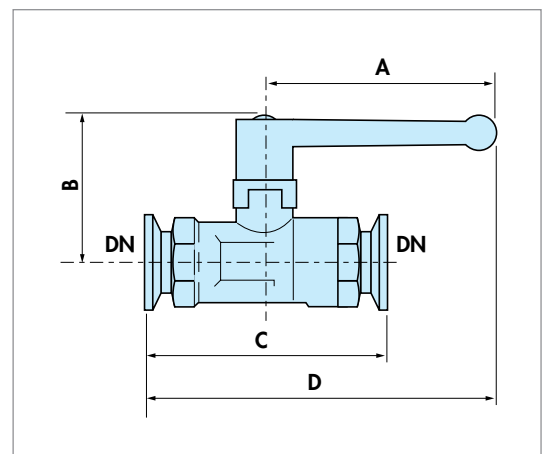

Special valves

Manual Vent Valves DN 10 - 16

Main Specifications

Stainless steel body

For venting small volumes

Leak rate:

- External $5 \cdot 10^{-8}$ mbar.l/s
- Seat $5 \cdot 10^{-8}$ mbar.l/s

Ordering information

Manual actuator

Flange DN		PART NUMBER ISO-KF
mm	inch	
16	5/8	786544
10/14	*	786200

* Smooth tube ID: 10 mm OD: 14 mm



Dimensions in mm

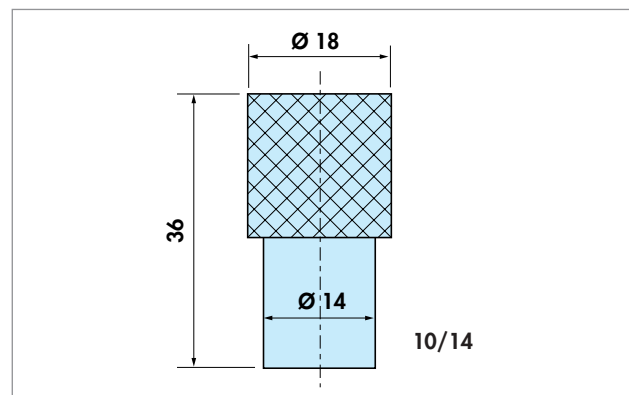
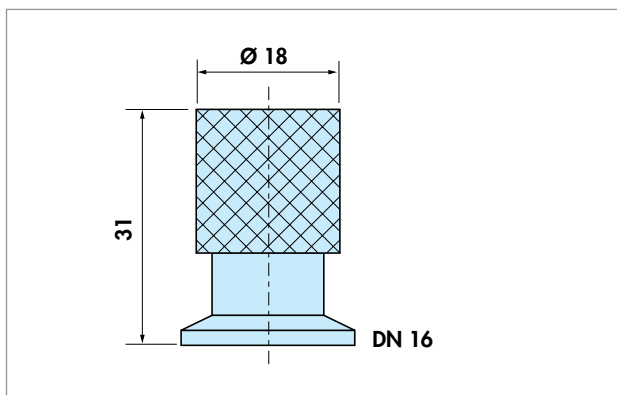

Special valves

Electromagnetic Isolation Valve DN 10

Main Specifications	
Leak rate:	
• External	10 ⁸ mbar.l/s
• Seat	10 ⁸ mbar.l/s
Material:	
• Body	Nickel plated brass
• Seals	FPM

Ordering information

Item	Voltage	PART NUMBER
Valve	230 V - 50/60 Hz	102743
	110/115 V - 50/60 Hz	100788
	200 V - 50/60 Hz	100789
	24 V 50/60 Hz	100790
	24 V DC	102604
Spare coil	230 V - 50/60 Hz	102607
	110/115 V - 50/60 Hz	102608
	200 V - 50/60 Hz	102609
	24 V 50/60 Hz	102610
	24 V DC	102611

Technical data

Flange	DN 10 - KF
I.D.	6 mm
Status power off	Closed
Closing time	10 to 15 ms
Conductance	2.5 l/s at 1 mbar
Venting time	7 s for 15 l 55 s for 100 l
Protection rate	IP 65
Electrical connector	DIN 43650
Nb of cycles	100 000



Dimensions in mm

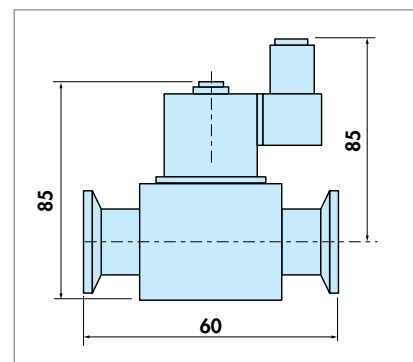
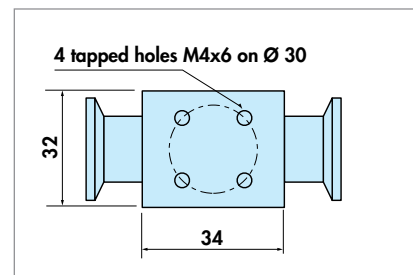

Special valves

Micro flow leak Valve DN 16

- Digital Flow indicator
- Quick on/off

Main Specifications

Stainless steel body	
Flange	DN 16 ISO-KF
Weight	0.4 kg
Settable gas flow	5.10 ⁻⁶ to 1000 mbar.l/s
Tightness	1.10 ⁹ mbar.l/s
Max. differential mesure	2.5 bar



Ordering information

Flange DN mm	PART NUMBER
16	305360

Dimensions in mm

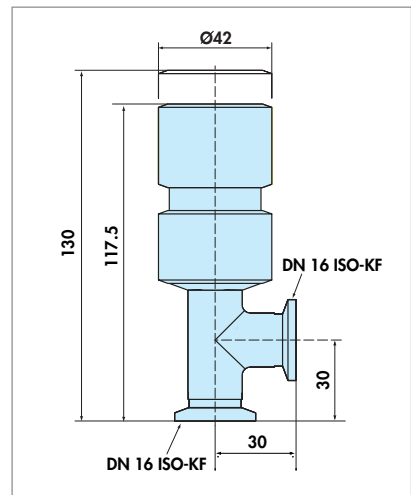

Technical data

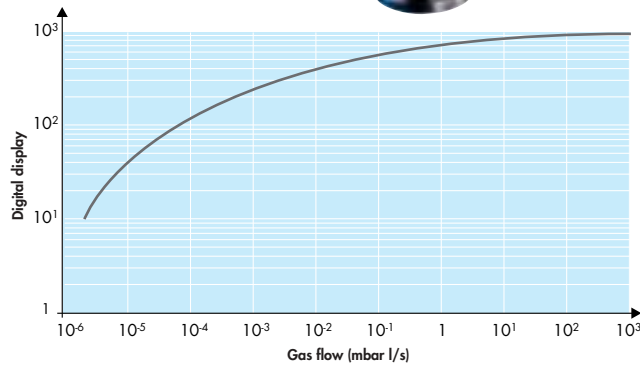

Leak Valve DN 16

Main Specifications

Brass body	
Flange	DN 16 ISO-KF
Weight	0.2 kg
Settable gas flow	10 to 100 mbar.l/s



Ordering information

Flange DN mm	PART NUMBER
16	786543

Dimensions in mm

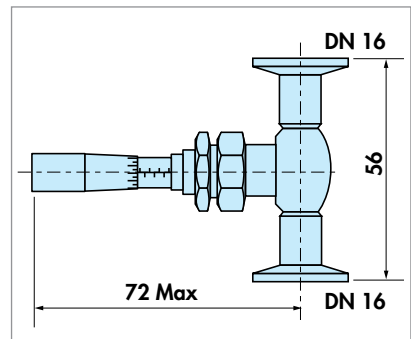

Technical data

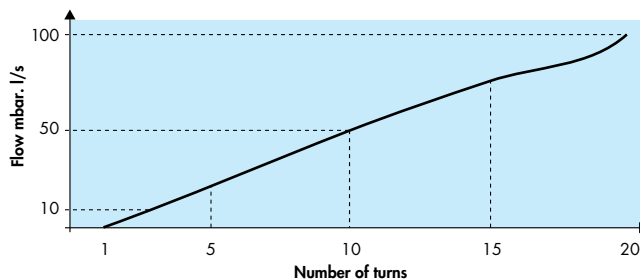

Special valves

Safety isolation valves DN 16 - 25

The ISV valve is used at the inlet of rotary vane pumps (4 to 20 m³/h) whenever isolation is required with vacuum circuit, in case of power failure.

In addition, the ISV acts as a venting valve for the rotary vane pump, while isolating the vacuum chamber. Suitable for neutral or slightly corrosive gas.

Features

- Total safety for pumping systems
- Low energy consumption
- Low dust production, thanks to slow return to atmospheric pressure
- Optional dry nitrogen gas, can be injected instead of air
- Operation in all positions
- Opens only when the inlet pressure of the pump is lower than the pressure into the vacuum chamber



Technical data

Weight: 0.640 kg
 Material: aluminium body - elastomer membrane
 Electrical supply: see ordering information
 Maximum working temperature: 40° C
 Flanges: DN 16 and DN 25 ISO-KF
 Leak rate: 10^{-4} mbar.l/s
 Air venting at closing: $7 \cdot 10^2$ mbar.l/s

Applications

Safety feature between rotary vane pumps and turbomolecular or diffusion pumps.
 Avoid hydrocarbon backstreaming from the rotary vane pump.

Ordering information

		PART NUMBER					
Flange DN	Model	220 V 50/60 HZ	240 V 50/60 HZ	100 V 50/60 HZ	100/115 V 50/60 HZ	200 V 50/60 HZ	24 V - DC
DN 16	ISV 16	033697	033683	033681	033680	033682	NC
DN 25	ISV 25	066832	066884	066883	066881	066882	066867
Spare coil		038121	038124	038126	038122	038125	038066

Special valves

Safety isolation valves DN 16 - 25

Operating principle

a/ Start-up conditions:

The different parts of the valve are at atmospheric pressure.
No power is supplied to electric coil.
The piston (4) is opened under pressure from return spring.

b/ Operating conditions:

The electrical coil is powered.
The solenoid valve (10) closes, isolating the upper chamber of the valve from external air.
The pumping is performed in the direction of the arrow ("pump").

Pressure in the chamber over the membrane (8) is progressively reduced (pressure reduction by the nozzle (6)). All valve elements are at pump inlet pressure.
The piston (4) is stable in the open position.

c/ Stoppage, during power failure:

The electrical coil is no longer powered and therefore immediately allows air at atmospheric pressure to enter the chamber over the membrane.

The piston (4) is pushed back, compressing the spring (7) and the valve closes.

The pumping unit gradually returns to atmospheric pressure via the open solenoid valve (10) and the nozzle.

Nota: on closing, a slight flow of air (around $7 \cdot 10^{-2}$ mbar.l/s) enters the vacuum chamber.

Spare parts

	P/N
Membrane	066838
O-Ring C 2 D 30	082252
Spring	066837

Conductance

Inlet pressure	
10^{-2} mbar	6 l/s
10^{-1} mbar	15 l/s
1 mbar	66 l/s

Dimension (mm)

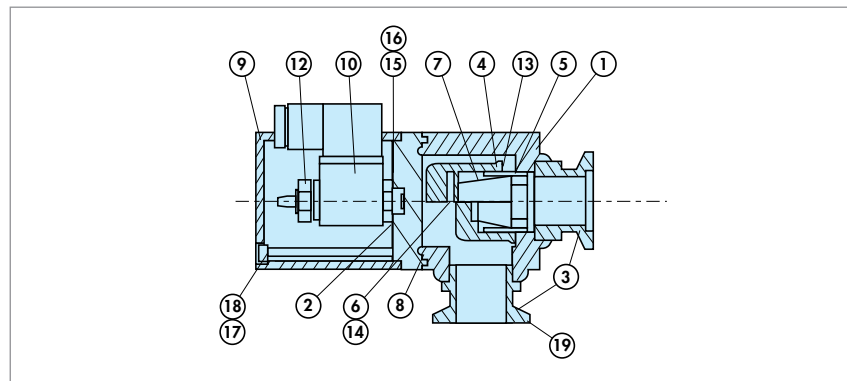
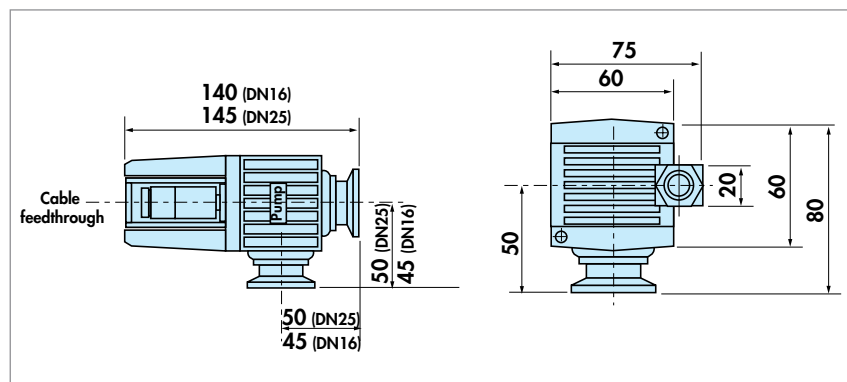



CHINA

Alcatel Vacuum Technology Shanghai
Tel: (86) 21 5027 0628
Fax: (86) 21 3895 3815

FRANCE

Alcatel Vacuum Technology France
Tel: 33 (0) 4 50 65 77 77
Fax: 33 (0) 4 50 65 77 89

GERMANY

Alcatel Hochvakuum Technik GmbH
Tel: (49) 9342 96 10 0
Fax: (49) 9342 96 10 30

ITALY

Alcatel Vacuum Systems S.p.a.
Tel: (39) 039 686 3855
Fax: (39) 039 667 125

JAPAN

Alcatel Japan
Tel: (81) 44 797 5920
Fax: (81) 44 797 5932

KOREA

Alcatel Vacuum Technology Korea
Tel: (82) 2 409 6277
Fax: (82) 2 409 6279

NETHERLANDS

Alcatel Vacuum Technology
Netherlands
Tel: (31) 306 35 13 60
Fax: (31) 306 35 12 21

SINGAPORE

Alcatel Singapore Pte Ltd
Tel: (65) 6254 0828
Fax: (65) 6254 7018

TAIWAN

Alcatel Vacuum Technology Taiwan
Tel: (886) 3 5599 230
Fax: (886) 3 5599 231

UNITED KINGDOM

Alcatel Vacuum Technology (U.K.)
Tel: (44) 1 506 418 000
Fax: (44) 1 506 418 002

USA

Alcatel Vacuum Products
Tel: (1) 781 331 4200
Fax: (1) 781 331 4230



Alcatel Vacuum Technology

98 Avenue de Brogny - BP 2069 - 74009 Annecy Cedex - France - Tel.: 33 (0) 4 50 65 77 77 - Fax: 33 (0) 4 50 65 77 89

www.adixen.com